

# Converting Vehicles to Propane Autogas

## Part 1: Installing Fuel Tanks and Fuel Lines





# Notice

---

*Users of this material should consult the law of their individual jurisdiction for the codes, standards and legal requirements applicable to them. This material merely identifies methods that the reader may find useful in implementing applicable codes, standards and legal requirements. This material is not intended nor should it be construed to:*

- (1) Set forth procedures which are the general custom or practice in the propane gas industry;*
- (2) Establish the legal standard of care owed by propane distributors to their customers;*
- (3) Prevent the reader from using different methods to implement applicable codes, standards or legal requirements.*

*This material was designed to be used as a resource only to assist expert and experienced supervisors and managers in training personnel in their organizations and does not replace federal, state, or company safety rules. The user of this material is solely responsible for the method of implementation. The Propane Education and Research Council and the Alternative Energy Division of the Railroad Commission of Texas assume no liability for reliance on the contents of this training material.*

*Issuance of this material is not intended to nor should it be construed as an undertaking to perform services on behalf of any party either for their protection or for the protection of third parties.*

*The use of specific products or manufacturers' trademarks, names or descriptions is for reference and not intended as an endorsement. The manufacturers' names, their products and component descriptive words and terminologies are trademarked and registered by their respective owners.*

---

*All rights reserved. No part of this text may be reproduced, utilized, or transmitted in any form or by any means, electronic or mechanical, including photocopying, recording, or by any information storage and retrieval system, without permission in writing.*

*© 2011 Propane Education & Research Council*

---

## **Caution!**



*Always consult recognized standards (NFPA 58 or equivalent) and Original Equipment Manufacturer (OEM) installation publications when working with propane autogas systems. Pressure in fuel tanks and other propane autogas system components may exceed 300 psig. Necessary safety precautions must be applied when installing, disconnecting or otherwise handling propane system components. Failure to apply adequate safety practices or failure to heed warnings while performing installation or repair procedures may result in serious personal injury or death to yourself or others.*



## Scope of This Course

This course, covering the installation of fuel tanks, transfer lines and fittings, is Part 1 of a suite of courses on retrofitting, servicing and fueling highway vehicles that run on propane autogas<sup>1</sup>. Part 2 covers the installation of under-hood components, and Part 3 covers the installation and operation of propane autogas dispensers.

The purpose of this course is not to teach the user how to convert a vehicle to propane, but to enable the user to compare the basic code requirements with other technologies and installation practices and use them as appropriate. At the time of this publication in the United States, the nationally recognized standards for vehicle conversions are found in National Fire Protection Association manual 58, *Liquefied Petroleum Gas Code* (NFPA 58). Some states have adopted additional or different code requirements. Users should check with the authority having jurisdiction in their areas to determine which requirements apply.

Additional references:

- CAN/CSA-B.149.5, Canadian Installation Code for Propane Fuel Systems and Tanks on Highway Vehicles
- EN67, the European standard for vehicles converted to LP gas

NOTE: Canadian or European conversion standards are referenced to demonstrate that other options are available and practiced worldwide. It is the installer's responsibility to determine the appropriate practice to use for each individual installation.

In every aspect of a propane equipment installation, where explicit equipment manufacturers' installation instructions exist, those instructions must be followed.

---

<sup>1</sup> "Propane autogas" or "autogas" is the term used internationally to refer to propane used as an engine fuel to propel on-road vehicles.

## Acknowledgments

The Propane Education and Research Council gratefully acknowledges the cooperation and contribution of the following individuals and organizations for providing personnel, equipment and technical assistance.

**Franz Hofmann**

Railroad Commission of Texas, Alternative Energy Division, P.O. Box 12967, Austin, Texas 78711, (512) 463-8501, [franz.hofmann@rrc.state.tx.us](mailto:franz.hofmann@rrc.state.tx.us)

**Steve Jaeger**

Railroad Commission of Texas, Alternative Energy Division, P.O. Box 12967, Austin, Texas 78711, (512) 463-9202, [steve.jaeger@rrc.state.tx.us](mailto:steve.jaeger@rrc.state.tx.us)

**Dan Kelly**

Railroad Commission of Texas, Alternative Energy Division, P.O. Box 12967, Austin, Texas 78711, (512) 463-7291, [dan.kelly@rrc.state.tx.us](mailto:dan.kelly@rrc.state.tx.us)

**Gordon Frey**

Frey Associates, 2295 Willingham Lane, Maryville, Tennessee 37803, (865) 233-0666, [gfacsm@charter.net](mailto:gfacsm@charter.net)

**Robert Myers**

Boulder, Colorado, (303) 449-0764, [remyers38@aol.com](mailto:remyers38@aol.com)

**Bill Platz**

Delta Liquid Energy, 1960 Ramada Drive, Paso Robles, California 93446, (805) 239-0616, [billp2@deltaliquidenergy.com](mailto:billp2@deltaliquidenergy.com)

**Gary Shepherd**

Stanford LP Gas, 3611 North Eastman Road, Midland, Michigan 48642, (989) 835-4754 [gashepherd@slpg.net](mailto:gashepherd@slpg.net)

**Bruce Swiecicki**

National Propane Gas Association, 1899 L Street NW, Washington, D.C. 20036, (202) 466-7200, [bswiczicki@npga.org](mailto:bswiczicki@npga.org)

**Michael Taylor**

Heritage Propane, 500 Meijer Drive, Suite 200, Florence, Kentucky 41042, (859) 647-4044, [Michael.Taylor@HeritagePropane.com](mailto:Michael.Taylor@HeritagePropane.com)

**Stuart Weidie**

Blossman Gas, P.O. Box 1870, Candler, North Carolina 28715, (828) 667-0437 [seweidie@blossmangas.com](mailto:seweidie@blossmangas.com)

# Credits

American Alternative Fuel..... Figure 44  
Frank Raso ..... Figures 32, 33, 34  
ICOM North America ..... Figures 38, 39  
National Fire Protection Association ..... Figure 14  
National Propane Gas Association ..... Table 1; Figure 7  
Propane Performance Industries, Ltd..... Figures 40, 41, 42, 43  
Roush CleanTech ..... Figures 57, 58, 59  
Sherwood Valve ..... Figure 66

<b>Scope of This Course .....</b>	<b>iii</b>
<b>Acknowledgments .....</b>	<b>iv</b>
<b>Credits .....</b>	<b>v</b>
<b>CHAPTER 1: Propane Fuel .....</b>	<b>2</b>
1.1.1 History of LP-Gas as an Engine Fuel.....	2
1.1.2 Changes in the Fuel Blend.....	2
1.1.3 Rapid Growth .....	3
1.1.4 Physical Characteristics and Properties.....	3
1.1.5 Heat Content.....	3
1.1.6 Odorant.....	4
1.1.7 Specific Gravity .....	4
1.1.8 Boiling Point, Temperature, and Pressure .....	5
1.1.9 Expansion Ratio .....	6
1.1.10 Flammability Limits .....	7
1.1.11 Combustion Air/Fuel Ratio.....	7
1.1.12 Octane Ratings.....	8
1.1.13 Combustion Characteristics .....	9
1.1.14 Emissions.....	9
1.1.15 Engine Performance .....	10
1.1.16 Engine Maintenance and Life.....	10
1.1.17 Propane Fuel Containers and Fuel Lines .....	10
Review of Chapter 1 .....	13
<b>CHAPTER 2: Basic Safety Considerations .....</b>	<b>16</b>
Review of Chapter 2.....	18
<b>CHAPTER 3: Pre-Conversion Inspection/Validation .....</b>	<b>20</b>
3.1 Validating a Vehicle Prior to Conversion .....	20
3.1.1 Pre-Conversion Checklist.....	20
3.1.2 Converting High-Mileage Vehicles.....	20
3.1.3 Pre-Conversion Test Drive.....	21
3.2 Vehicle Sign-In Form—All Vehicles .....	23
3.2.1 Vehicle Checklist After Customer Sign-In .....	24
Review of Chapter 3.....	27
<b>CHAPTER 4: Tanks .....</b>	<b>30</b>
4.1 Tanks and Tank Installations .....	30
4.1.1 Open Vehicle Tank Installations.....	33
4.1.2 ASME Tank Working Pressures .....	33
4.1.3 Enclosed Vehicle Installations.....	34
4.2 Tank Selection .....	34
4.2.1 Size Considerations.....	35



# Table of Contents

4.2.2 Range Considerations .....	35
4.2.3 Placement Considerations.....	36
4.2.4 Tank Locations .....	36
4.3 Purging .....	37
4.3.1 Pressure Purge .....	38
4.4 Installation Requirements and Options .....	40
4.4.1 Universal Installation (“Slick” Tank) .....	43
4.4.2 Tanks Located on the Vehicle .....	44
4.4.3 Fuel Tanks Located Under the Vehicle .....	45
4.4.4 Fuel Tanks Located Inside the Vehicle .....	47
4.4.5 Hose Routing .....	49
4.4.6 Other Tank Options.....	49
4.5 Tank Installation Process .....	51
4.5.1 Underbody Access.....	52
4.5.2 Nut and Bolt Torque.....	53
Review of Chapter 4.....	54
<b>CHAPTER 5: Fuel Transfer Lines.....</b>	<b>58</b>
5.1 Standards .....	58
5.2 Type III Hose.....	59
5.3 Fuel Line Mounting and Routing .....	61
Review of Chapter 5.....	65
<b>CHAPTER 6: Fuel-Line Connectors .....</b>	<b>68</b>
6.1 Tapered Thread Fittings and Sealants .....	68
6.2 Fuel Line Fittings.....	70
6.3 Additional Fuel-Line Requirements .....	71
Review of Chapter 6.....	73
<b>Appendix A: Material Safety Data Sheet.....</b>	<b>76</b>
<b>Appendix B: On-Board Diagnostics .....</b>	<b>84</b>
<b>Appendix C: Pre-Conversion Guidelines .....</b>	<b>86</b>
<b>Appendix D: Purging Propane Autogas Tanks With a Vacuum Pump.....</b>	<b>89</b>
<b>Appendix E: Glossary .....</b>	<b>90</b>



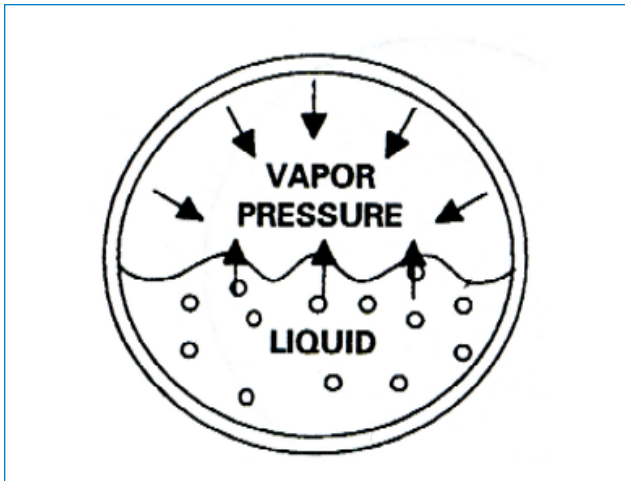
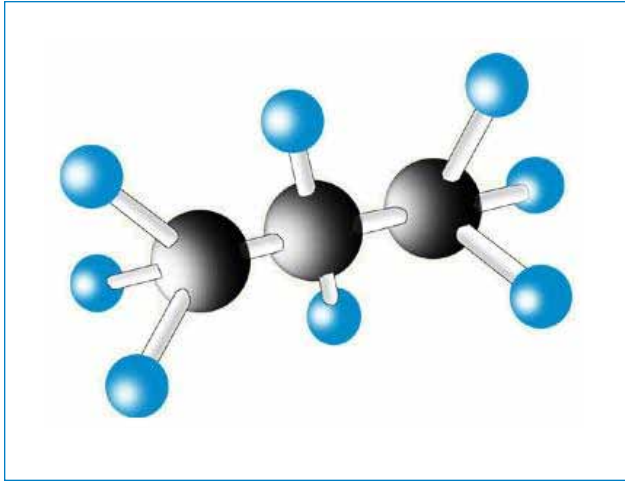

# **Chapter One**

## **Propane Fuel**

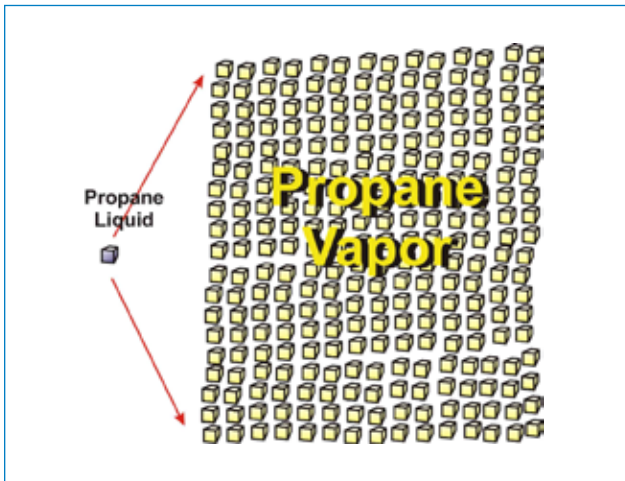

## CHAPTER 1: PROPANE FUEL

### 1.1.1 History of LP-Gas as an Engine Fuel

The use of LP-gas (liquefied petroleum gas) as an engine fuel is almost as old as the automobile itself. In the early 1900s, the main fuels available to power automobiles were gasoline and grain alcohol (ethanol). Gasoline rapidly became the overwhelming choice because of its price advantage and widespread availability, even though the refining practices of that time made it a highly volatile fuel that evaporated quickly.

Dr. Walter Snelling of the U. S. Bureau of Mines discovered a method of removing the lighter hydrocarbons from gasoline. He later identified these compounds as butane and propane, the primary constituents of LP-gas. The result improved motor gasoline and created a new LP-gas industry.

Dr. Snelling and his colleagues also devised methods for liquefying LP-gas. A practical means of separating butane and propane from crude oil and natural gas was developed, and the first automobiles powered by LP-gas appeared in the early 1900s.

### 1.1.2 Changes in the Fuel Blend

Until World War II, LP-gas engine fuel was mainly butane. The discovery of new uses for butane in gasoline blending and the petrochemical industry, however, shifted most of the available butane away from the engine fuel market. Propane became the primary component of LP-gas engine fuel.

In 1963 the Gas Processors Association (GPA) adopted specification HD-5 for propane engine fuel. The purpose was to provide a uniform quality propane, so engines could be designed and tuned to deliver the best performance and fuel economy. The specification is in GPA Standard 2140-97, Liquefied Petroleum Gas Specifications and Test Methods. It is incorporated as “special duty propane” in ASTM D-1835, Standard Specification for Liquefied Petroleum (LP) Gases.

The letters HD in HD-5 stand for “Heavy Duty,” and the number 5 represents the maximum percentage of propylene allowed in the fuel blend. HD-5 must be at least 90 percent propane and may contain up to 2.5 percent butane and heavier hydrocarbons by liquid volume. HD-5 must be essentially free from oily residues and other contaminants such as sulfur. A maximum vapor pressure of 208 psig at 100°F (Reid method) effectively limits ethane content.

HD-10 is the unofficial term for LPG with up to 10 percent propylene that meets the specifications set out in the California Code of Regulations, Title 13, Section 2292.6.

### 1.1.3 Rapid Growth

The 1973 Arab Oil Embargo increased public interest in propane engine fuel. Suddenly gasoline was in uncertain supply and expensive, resulting in rapid growth of propane fuel-system retrofits in the late 1970s and early 1980s. By 1978 about 35,000 vehicles a year were being converted to propane in the U.S. By 1981 that number was nearly 250,000. In 1989 almost 4 million vehicles worldwide were powered by propane autogas.

Regulatory actions increased demand for alternative-fueled vehicles in the 1990s. Some states, such as Texas, Florida, and California, required the use of these fuels as early as 1989. With the 1990 amendments to the Clean Air Act, the United States required the use of alternative fuels in certain fleets. Although the price gap between gasoline and propane has subsequently narrowed, environmental concerns and cost savings continue to motivate fleets to convert their vehicles.

### 1.1.4 Physical Characteristics and Properties

Like gasoline and diesel fuel, propane is a member of the hydrocarbon (HC) family. HC's are substances whose molecular structure is composed solely of hydrogen and carbon.

There are literally thousands of different HC's, ranging from those found in asphalts, heavy oils and waxes to gasoline, kerosene, naphtha and light gases such as methane, ethane, propane and butane. Gasoline is a mixture of 40 to 400 or more different HC's.

The number and arrangement of hydrogen and carbon atoms in a fuel's molecular structure is what gives each fuel its set of physical properties. At atmospheric pressure, propane ( $C_3H_8$ ), butane ( $C_4H_{10}$ ) and methane ( $CH_4$ ) are gases because of their relatively low molecular weight. At atmospheric pressure, gasoline, kerosene and diesel fuel are liquids because their molecules are much larger and heavier.

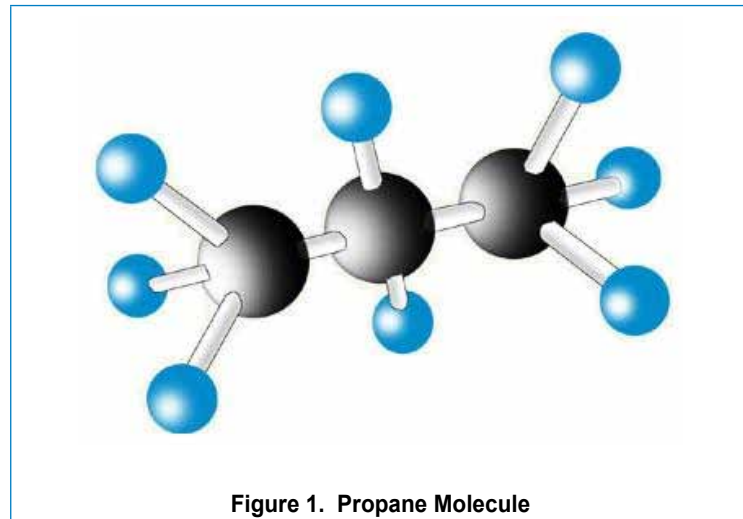

Figure 1. Propane Molecule

### 1.1.5 Heat Content

Heating values are measured in British thermal units (Btu's). One Btu is the amount of heat required to raise the temperature of one pound of water one degree Fahrenheit.

Generally speaking, the more carbon atoms in a molecule of a given fuel, the greater its heat content or energy value. Table 1 on page 12 shows how much heat is produced when a given quantity of propane is burned. One gallon of propane will produce 91,502 Btu's of heat energy, compared to 114,264 Btu's for one gallon of gasoline. By weight, one pound of propane produces 21,548 Btu's, which is almost the same as gasoline.

Although propane produces almost as much heat energy as gasoline on a per-pound basis, propane weighs about two pounds less per gallon than gasoline. An engine's horsepower output depends on the quantity (mass) of fuel burned, so even though propane requires a leaner air/fuel mixture than gasoline, the net result is that it takes more propane than gasoline by volume to achieve the same power output.

Gasoline engines converted to propane will generally consume 15-25 percent more fuel, in terms of miles per gallon.

### 1.1.6 Odorant

Propane is odorless by nature, like butane or methane. An odorant, usually ethyl mercaptan, is added to give propane its distinctive, pungent smell. The odorant acts as a warning agent so that leaks can be detected quickly. It is not harmful to breathe, nor does it affect the composition of the fuel in any way except to make its vapors noticeable. Once the fuel is burned, the odor disappears.

NFPA 58 states that odorization at the rate of one pound of ethyl mercaptan per 10,000 gallons of propane has been recognized as an effective odorant. This rate allows the average person to detect a combustible mixture of air and fuel at a level of not more than 1/5 the lower flammability limit (2.1 percent fuel to air).<sup>1</sup>

### 1.1.7 Specific Gravity

Propane liquid is lighter than water, and propane vapor is heavier than air. These physical characteristics are expressed as specific gravities.

The specific gravity of a liquid is defined as the weight of a given volume of the liquid compared to the weight of the same volume of water, measured at the same temperature and pressure.

The specific gravity of water is defined as 1.0. A liquid that is twice as heavy as water has a specific gravity of 2.0, and a liquid that is half as heavy has a specific gravity of 0.5. The specific gravity of propane liquid is 0.504, which means propane liquid weighs about half as much as water.

Similarly, the specific gravity of a gas (vapor) is defined as the weight of a given volume of the vapor compared to the weight of the same volume of air, measured at the same temperature and pressure.

The specific gravity of air is defined as 1.0. A vapor that is twice as heavy as air has a specific gravity of 2.0, and a vapor that is half as heavy as air has a specific gravity of 0.5. The specific gravity of propane vapor is 1.50, which means propane vapor weighs half again as much as air.

<sup>1</sup> NFPA 58, 2008 and 2011 eds., §4.2.1

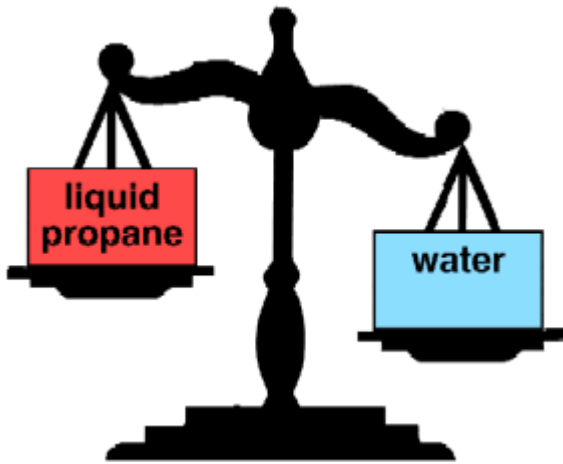

Figure 2. Propane liquid is lighter than water.

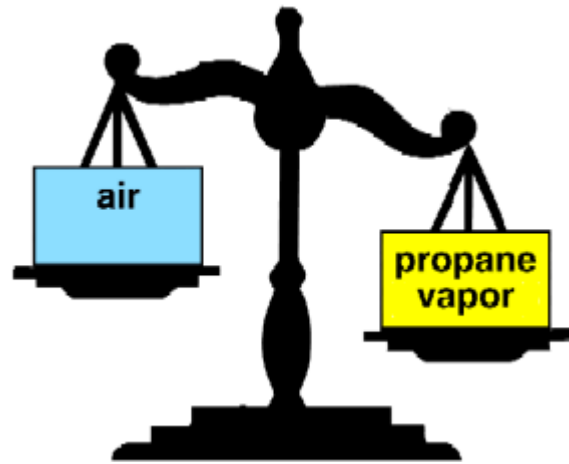

Figure 3. Propane vapor is heavier than air.

The specific gravity of propane vapor is an important physical property. Propane vapor is heavier than air. Therefore, it tends to initially accumulate at the lower level of spaces when it is released into a still environment. Sources of ignition, such as open flames, must be controlled in accordance with NFPA 58 wherever propane-fueled vehicles are parked or serviced indoors.

Repairs must be made either outdoors or in a well-ventilated area at least 25 feet away from any sources of ignition, such as smoking materials, open flames, electrical tools and lights, and at least 35 feet away from any metal grinding or oxy-welding operation. Fueling and venting operations must be performed only outdoors, and unauthorized personnel should be kept away from the repair area.

### 1.1.8 Boiling Point, Temperature, and Pressure

Another important physical property of propane is its low boiling point. At standard atmospheric pressure (sea level), pure propane liquid boils (vaporizes) at any temperature warmer than  $-44^{\circ}\text{F}$ . Below  $-44^{\circ}\text{F}$ , propane will remain liquid at standard atmospheric pressure.

At temperatures above  $-44^{\circ}\text{F}$ , propane will exist as a vapor unless it is kept under pressure, as in a container. Propane stored in a container exists as both a vapor and a liquid.

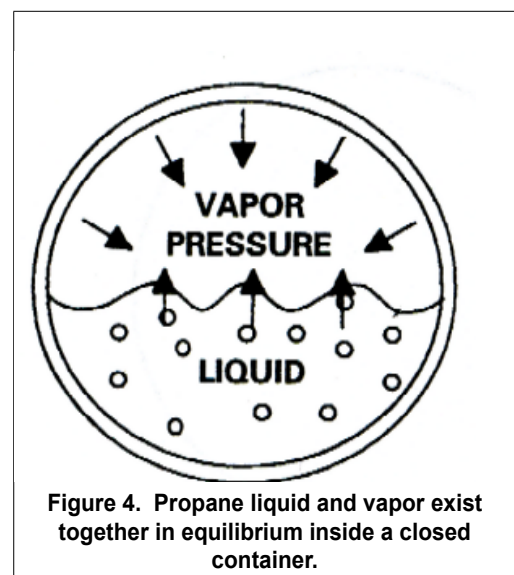

Figure 4. Propane liquid and vapor exist together in equilibrium inside a closed container.

The amount of pressure required to keep propane a liquid increases with temperature. At  $-20^{\circ}\text{F}$ , for example, very little pressure (only 10.7 psi) is required, because  $-20^{\circ}\text{F}$  is fairly close to propane's natural boiling point of  $-44^{\circ}\text{F}$ . At  $100^{\circ}\text{F}$ , however, 205 psi of pressure is required to keep propane a liquid, because the fuel is far above its boiling point. Figure 8 on page 11 shows the vapor pressure of propane at different temperatures.

If propane vapor or liquid is released from a container, the pressure in the container is reduced temporarily, causing the liquid propane to boil and generate vapor to fill the space above the liquid. Vaporization continues until a state of equilibrium is reached. When liquid is added to the container, the rising liquid compresses the gas in the vapor space, increasing the pressure inside the container. The propane vapor then starts condensing to liquid in order to restore equilibrium at that temperature. Propane inside a sealed tank will remain a liquid as long as the pressure is maintained.

Lowering the temperature lowers the vapor pressure inside a closed fuel tank, just as increasing the temperature raises the pressure. For this reason, hot days, cool nights, direct sunlight, rain and snow all affect the vapor pressure of the fuel inside a tank.

It is not unusual to see tank pressures change as much as 50 psi in the course of a day.

### 1.1.9 Expansion Ratio

The reason why propane is stored as a liquid under pressure is to save space. Liquid is denser than vapor, so much more fuel can be stored in a tank if the propane is in liquid form.

Like other liquids, propane expands when heated. But not all liquids expand at the same rate. Propane expands approximately one percent for each  $6^{\circ}\text{F}$  increase in its temperature.

To allow for expansion, propane fuel tanks are never completely filled with liquid. They are filled to approximately 80 percent of capacity to allow room for thermal expansion. Fuel tanks are also equipped with pressure relief valves that vent propane vapor if the internal tank pressure exceeds the preset rating of the valve. The valve closes automatically when internal pressure is reduced below this start-to-discharge pressure.

If propane liquid is released into the air, it quickly vaporizes and expands to 270 times its original volume. Therefore, a liquid propane leak can be more hazardous than a vapor leak due to the expanding vapor cloud.

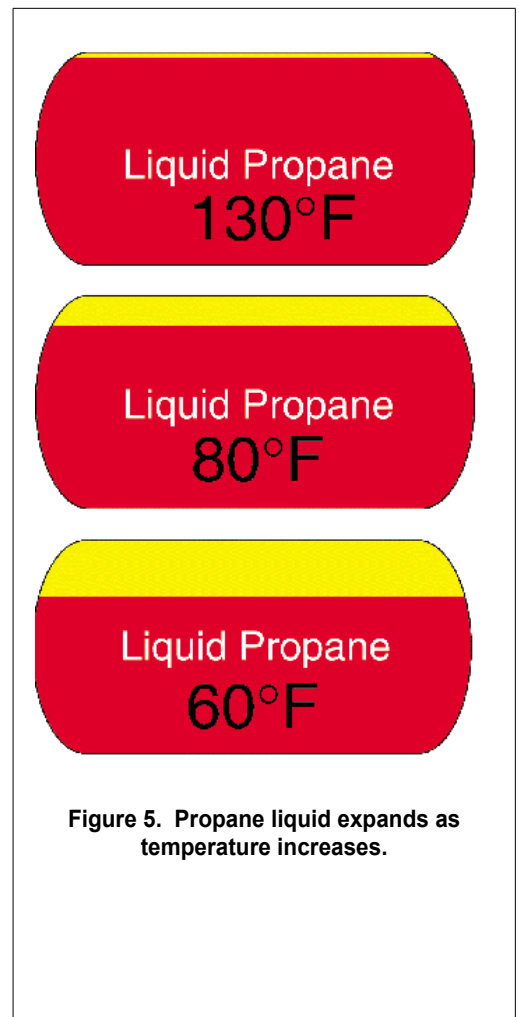

Figure 5. Propane liquid expands as temperature increases.



Also, when liquid propane is released into the atmosphere, its rapid vaporization pulls heat from the surrounding air, causing a refrigerating effect that makes everything it touches extremely cold. If propane liquid contacts skin or other tissues, it can cause third-degree freeze burns.

### 1.1.10 Flammability Limits

A flammability limit is the lowest or highest percentage of fuel needed in an air/fuel mixture to support combustion. Combustion occurs when an air/fuel mixture that is within the flammability limits is ignited, e.g., by heat from a spark or compression.

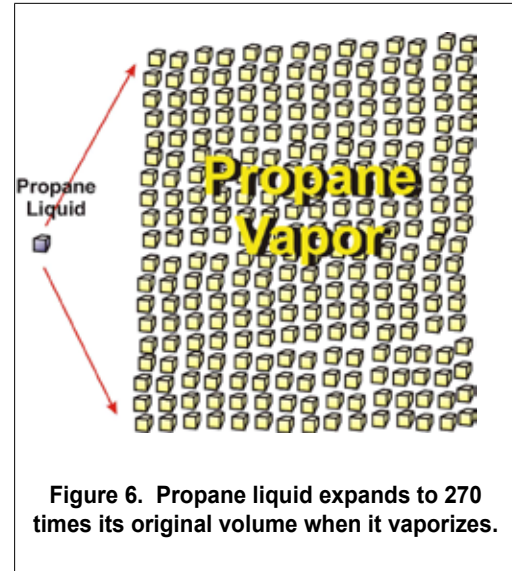

Figure 6. Propane liquid expands to 270 times its original volume when it vaporizes.

Flammable air/fuel mixtures fall between the upper and lower flammability limits. The upper flammability limit is the greatest concentration of fuel—the richest air/fuel mixture—that will support combustion. Air/fuel mixtures above the upper limit will not burn because there is too much fuel and not enough air.

The lower flammability limit is the minimum concentration of fuel—the leanest air/fuel mixture—that will support combustion. Air/fuel mixtures below the lower limit will not burn because there is too much air and not enough fuel.

See Table 1 for the flammability limits of propane.

### 1.1.11 Combustion Air/Fuel Ratio

Although propane vapor will burn in any mixture within its limits of flammability, combustion is most efficient and complete when there is just the right amount of fuel for the available oxygen in the air. The ideal combustion ratio for propane, also referred to as the stoichiometric<sup>2</sup> air/fuel ratio, is 15.5:1 by weight, i.e., 15.5 pounds of air for every pound of propane vapor. The ratio is 24:1 by volume, i.e., 24 parts of air (96 percent) to every one part of propane vapor (4 percent). See Table 1.

An air/fuel mixture that is richer than the ideal ratio lacks enough oxygen to burn the fuel completely. The resulting partial combustion forms carbon monoxide (CO) and adds unburned HC's to the exhaust emissions. Fuel economy suffers because excess fuel is being used. Richer mixtures tend to produce more power up to a certain point, but the trade-off is reduced performance and economy, increased exhaust emissions and higher exhaust temperatures.

<sup>2</sup> The term “stoichiometry” is used to describe complete combustion. SAE standard J1829 defines “stoichiometric air-fuel ratio” as “the mass of air required to burn a unit mass of fuel with no excess of oxygen or fuel left over.” See [http://standards.sae.org/j1829\\_200210/](http://standards.sae.org/j1829_200210/).

If an air/fuel mixture is too lean, a condition known as lean misfire can occur inside the engine. Although the mixture may be above the lower flammability limit, it may be too lean for the spark to ignite. This allows unburned fuel vapors to pass through into the exhaust, increasing HC emissions. Performance is reduced because of the misfire, and economy suffers because of the wasted fuel.

### 1.1.12 Octane Ratings

Octane ratings measure a fuel's resistance to detonation. Propane's pump octane rating (100-105) is higher than that of any premium gasoline.

Detonation occurs when the pressures inside the combustion chamber become too great for the fuel to burn evenly. Instead of a smoothly expanding flame front inside the cylinder, multiple flame fronts are formed and collide with one another, producing a sharp pinging or spark knock that signals detonation. Vibration created by these colliding flame fronts can quickly damage an engine.

A fuel's resistance to detonation may be expressed in three different ways: research octane, motor octane, and pump octane. Research octane rating is determined in a laboratory by comparing the fuel's detonation resistance to that of two known test fuels: iso-octane (100 octane, the highest grade) and normal heptane (0 octane, the lowest grade). The fuel being tested is assigned a value relative to the ratio of a mixture of iso-octane to heptane that results in the equivalent knock resistance. The research method yields the highest octane rating of the three methods.

Motor octane ratings more accurately describe a fuel's resistance to detonation in actual service. In the motor octane test, the test fuel is evaluated in an engine that simulates actual driving conditions, resulting in lower octane numbers.

Pump octane is the rating posted on a fuel dispenser. It is calculated as  $R + M / 2 = P$ , or the sum of research octane and motor octane divided by 2 equals pump octane. The pump octane method yields average results of:

- Regular unleaded gasoline = 87 octane
- Mid-grade unleaded gasoline = 89 octane
- Premium unleaded gasoline = 91-93 octane
- Propane (HD-5 / HD-10) = 100-105 octane (rating varies with the percentage of propane and other LP-gases)

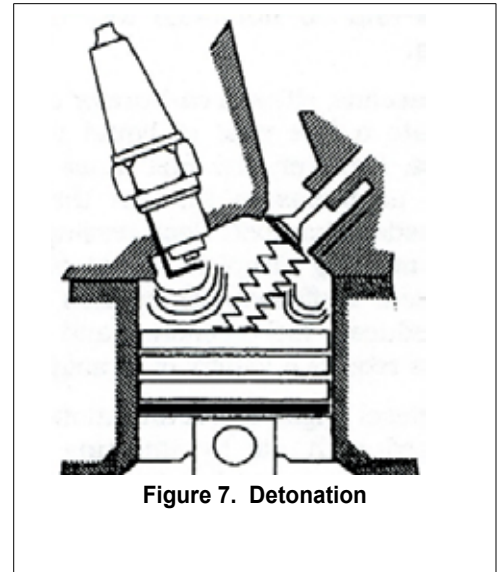

### 1.1.13 Combustion Characteristics

Propane is a vapor at standard temperature (60°F) and standard atmospheric pressure (one atmosphere or 14.7 psi absolute). Gasoline and diesel fuel are liquids under these conditions. They must be vaporized to burn well.

In a gasoline fuel system, a carburetor or fuel injector creates a fine mist of liquid fuel. To vaporize completely, the fuel must pick up additional heat as it passes through the intake manifold and enters the combustion chamber. Compressing the fuel helps the droplets of gasoline mix and vaporize. If gasoline is not completely vaporized, inefficient combustion causes higher exhaust emissions and reduces fuel economy and performance. Therefore, gasoline engines require a variety of strategies to aid cold-starting.

With diesel engines, the situation is somewhat different. Diesel fuel is mixed with air by injecting it directly into the combustion chamber or pre-chamber as a highly pressurized mist. The fuel is not injected until the air inside the combustion chamber has been compressed and is extremely hot (around 1,000°F). Injection occurs a few degrees before the piston reaches top dead center on the compression stroke. The diesel fuel ignites the instant it hits the hot air. But because there is little time for the air and fuel to mix, diesel combustion is incomplete. As a result, diesels sometimes emit a lot of soot and other pollutants in their exhaust. For cold starting, a diesel engine must be cranked fast enough to heat the air inside the cylinders to the point where it will ignite the fuel. A glow plug system is required on many engines to provide the initial starting heat. Lighter grade diesel fuel must also be used during cold weather to prevent waxing and clogging of fuel lines and injectors.

Propane has excellent cold-start properties, because it enters the engine as a vapor at temperatures as cold as -40°F. This eliminates the need for cold-starting aids and allows the fuel to mix readily with air for efficient and clean combustion.

### 1.1.14 Emissions

All internal combustion engines produce emissions, but some fuels produce less than others. The main regulated compounds in engine exhaust are hydrocarbons (HC's), carbon monoxide (CO), and various oxides of nitrogen (NOx). Some jurisdictions also regulate emissions of carbon dioxide (CO<sub>2</sub>).

In addition to catalytic converters that treat exhaust, late-model passenger cars and most light- and medium-duty trucks have charcoal canisters that trap evaporative emissions from the gasoline fuel tank. These vapors are drawn into the engine and burned when the engine is started. Although the canisters absorb much of the fuel vapor, a saturated canister can still release raw HC's into the atmosphere. Studies indicate that HC's may account for as much as 20 percent of total emissions from a vehicle.

Propane fuel systems are sealed to maintain pressure and are therefore less likely to produce evaporative emissions.

## 1.1.15 Engine Performance

Many engines perform better on propane than on gasoline. One reason is that propane mixes more readily with air. Propane's higher octane rating also allows the engine to use a more aggressive ignition timing curve at lower rpm and still resist detonation. On engines where timing is controlled by an on-board computer, some propane fuel systems use a modified OEM computer that has been reprogrammed with a new fuel and ignition timing map.

Another factor that contributes to increased performance is a denser air/fuel mixture entering the cylinders. Since propane is already vaporized when it enters the intake manifold, heating is not necessary or desirable. Lower intake temperatures promote a denser mixture for more power.

## 1.1.16 Engine Maintenance and Life

Clean combustion extends spark plug life, decreases valve train wear, and reduces wear on internal engine components, thus extending engine life and reducing maintenance costs.

When sludge and acid build up as a result of combustion blow-by, especially during engine warm-up, additives in the engine oil are rapidly used up. Bearings, rings, valve guides, cam lobes, and other friction surfaces wear more rapidly as the lubricant breaks down. Propane virtually eliminates the buildup of carbon, varnish and sludge inside the engine. Fewer contaminants in the crankcase means that oil change intervals may be safely extended.

Specially formulated oils are available with additive packages designed for propane-powered engines. Additives that are used in regular motor oils to disperse acids and varnish are not necessary in a propane-powered engine; in fact, they can form harmful deposits on the valves. Propane engine oils also contain additives that prevent the oil viscosity from changing or thickening when change intervals are extended.

Oils designed for propane service are not recommended for bifuel applications.

## 1.1.17 Propane Fuel Containers and Fuel Lines

Propane autogas containers are designed and built to American Society of Mechanical Engineers standards for pressure vessels. ASME tanks are significantly stronger and more resistant to damage or punctures than conventional gasoline fuel tanks.

Propane tanks store propane under pressures similar to those in conventional automotive air-conditioning systems, truck air-brake systems or large truck tires. The tanks are rated for more than 3<sup>1</sup>/<sub>2</sub> times their maximum working pressure (960 psig burst pressure, or more).

Propane moves from the tank to the engine through fuel lines that are rated for more than five times their maximum anticipated working pressure (350 psig working pressure, 1,750 psig burst pressure, or more).

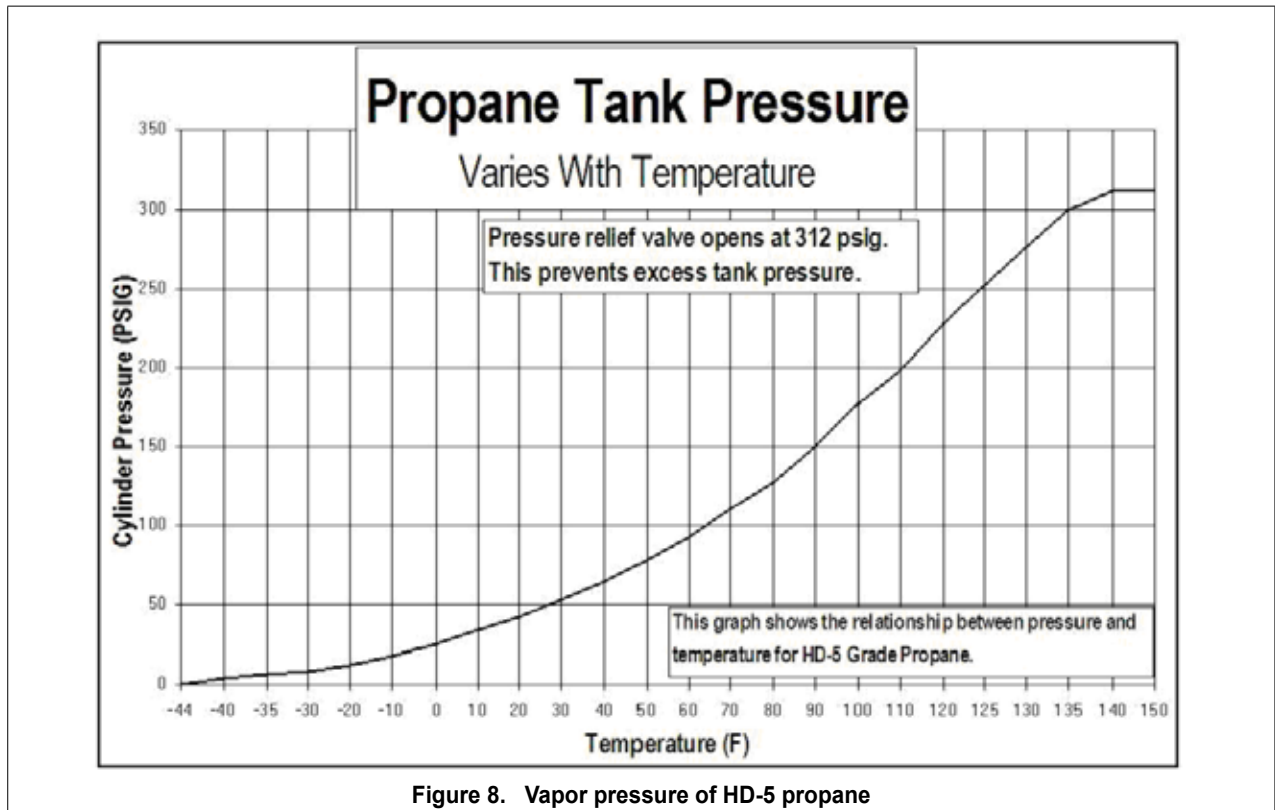

Figure 8. Vapor pressure of HD-5 propane

Vapor Pressure. The vapor pressure of propane in a container varies with temperature. Figure 8 shows propane's vapor pressure index (VPI).

Table 1. Physical Properties of Propane

Chemical Formula	C <sub>3</sub> H <sub>8</sub>
Vapor Pressure at:	(in psig)
-44°F	0
-20°F	10.7
70°F	127
100°F	196
105°F	210
130°F	287
Specific gravity of liquid at 60°F	0.504
Initial boiling point at 14.7 psig in °F	-44°F
Weight per liquid gallon at 60°F	4.20 lbs
Specific heat of liquid (BTU/lb at 60°F)	0.63
Cu. ft. of vapor per liquid gallon at 60°F	36.38
Cu. ft. of vapor per pound at 60°F	8.66
Specific gravity of vapor (air = 1) at 60°F	1.5
Ignition temperature in air	920-1120°F
Maximum flame temperature in air	3,595°F
Limits of flammability in air, in % of gas to air	2.1% to 9.6% (lean and rich limits)
Ideal air-to-fuel ratio by volume	24:1
Ideal air-to-fuel ratio by weight	15.5:1
Latent heat of vaporization at boiling point	
BTU per pound	184
BTU per gallon	773
Total heating value after vaporization	
BTU per cubic foot	2,488
BTU per pound	21,548
BTU per gallon	91,502
Octane ratings	
Research	110
Motor	95
Pump	103

## Review of Chapter 1

**Directions:** Select from the list below the response that most correctly completes each of the following statements. Write the letter of your choice in the space provided. Answers may be used more than once.

- |                |              |
|----------------|--------------|
| A. -44         | J. 10        |
| B. heavier     | K. frostbite |
| C. colorless   | L. 0.504     |
| D. 1           | M. 1.50      |
| E. 1 1/2%      | N. lighter   |
| F. 24          | O. 270       |
| G. 15.5        | P. 1/2       |
| H. natural gas | Q. 6         |
| I. NFPA 58     | R. 1.5       |

- \_\_\_ 1. Propane vapor is \_\_\_\_\_ than air.
- \_\_\_ 2. Propane liquid weighs \_\_\_\_\_ as much as water.
- \_\_\_ 3. Propane expands in volume \_\_\_\_\_ times when it boils and changes from liquid to vapor.
- \_\_\_ 4. The specific gravity of propane vapor is \_\_\_\_\_.
- \_\_\_ 5. The stoichiometry ratio for propane by weight is \_\_\_\_\_:1.
- \_\_\_ 6. Propane is produced by the processing of crude oil and/or \_\_\_\_\_.
- \_\_\_ 7. Propane liquid is \_\_\_\_\_ than water.
- \_\_\_ 8. The boiling point of propane liquid at normal atmospheric pressure is \_\_\_\_\_ degrees F.
- \_\_\_ 9. The ideal air-to-fuel ratio of propane by volume is \_\_\_\_\_:1.
- \_\_\_ 10. The specific gravity of propane liquid is \_\_\_\_\_.
- \_\_\_ 11. Liquid propane can cause \_\_\_\_\_ when it comes in contact with body tissue.
- \_\_\_ 12. Propane liquid expands approximately \_\_\_\_\_ percent for every \_\_\_\_\_ degrees F increase in temperature.
- \_\_\_ 13.

Answers: 1-B, 2-P, 3-O, 4-M, 5-G, 6-H, 7-N, 8-A, 9-F, 10-L, 11-K, 12-D, 13-Q





# ***Chapter Two***

## ***Basic Safety Considerations***

## CHAPTER 2: BASIC SAFETY CONSIDERATIONS

1. Propane is classified as a hazardous material. By law, a Material Safety Data Sheet (MSDS) must be available and accessible to all employees in the workplace or business by request wherever hazardous materials are transferred, stored, or used. An MSDS for propane is available from propane suppliers or distributors. A generic MSDS for propane is included as Appendix A of this manual.
2. Propane released to the atmosphere is combustible within its flammability limits. The point where propane is transferred must be at least 25 feet away from any source of ignition and at least 35 feet away from any metal grinding or oxy-welding operation<sup>1</sup>. All unauthorized persons (potential ignition sources) should be kept at least 25 feet away from any tank venting or discharge areas.
3. All releases of propane should be performed outdoors in a well-ventilated area, downwind and away from any buildings or premises that may be occupied. Controlled flaring—combustion using proper equipment and performed by qualified persons—may be appropriate in some cases. Other persons in the area should be advised to keep out of the release area to prevent introduction of unidentified and unanticipated sources of ignition.

Discharged gas under controlled conditions must be burned off under controlled conditions or captured and returned to an auxiliary tank for both safety and environmental reasons.

4. Propane is clear, colorless and odorless in its natural state. Propane is a non-toxic gas, but if inhaled in sufficient quantities, it may cause disorientation or ultimately, death due to displacement of oxygen. A man-made odorant, typically ethyl mercaptan, a sulfur-based compound, is added to propane prior to wholesale distribution. The odorant aids in the detection of a combustible mixture of air and fuel by a person with a normal sense of smell at 1/5 of the lower limit of flammability.
5. Since propane is heavier than air, the greatest concentration of propane and combustible propane-air mixtures may initially be at ground level, even though the odor may initially be barely detectable at higher levels or in surrounding areas.
6. Pressures may exceed 300 psig in a propane autogas fuel tank. The pressure varies with the temperature of the air around the tank and any other heat added from sources such as fuel pumps, recirculated fuel, vehicle exhaust systems, solar radiation or road surfaces.

When liquid propane is released to any pressure below the storage pressure, it expands, absorbing heat from its surroundings, and its temperature momentarily decreases. If the pressure is allowed to drop to zero, propane will auto-refrigerate to its boiling point, which is 44 degrees below zero Fahrenheit (−44°F). Contact with liquid propane can cause immediate frostbite. Exposure to liquid propane must be prevented by wearing suitable protective

<sup>1</sup> NFPA 58, 2008 and 2011 eds.; §§7.2.3.2(B) and 7.2.3.2(C)

clothing, including gloves and safety eyewear.

7. The use of personal protective equipment should be mandatory whenever installing or servicing a propane fuel system or tank.
  - Drilling, grinding, welding, and working under a vehicle can produce flying metal, dirt, and debris. Safety glasses are mandatory.
  - Safety standards for working with propane are covered in NFPA 58, *Liquefied Petroleum Gas Code*, as adopted by the authority having jurisdiction.

Special precautions must be used and maintained to prevent injury, including wearing protective gloves, safety eyewear and hearing protection.

## Review of Chapter 2

**Directions:** Select from the list below the response that most correctly completes each of the following statements. Write the letter of your choice in the space provided. Items shown in this list may represent information shown prior to Chapter 2.

- |                         |                                  |
|-------------------------|----------------------------------|
| A. unauthorized persons | E. Personal Protective Equipment |
| B. frostbite            | F. 25 feet                       |
| C. one fifth (1/5)      | G. non-toxic                     |
| D. MSDS                 | H. -44°F                         |

- \_\_\_ 1. Propane has an auto-refrigeration temperature (boiling point) of \_\_\_\_\_.
- \_\_\_ 2. Ignition sources must be eliminated within \_\_\_\_\_ of a propane-fueled vehicle work area.
- \_\_\_ 3. Released propane liquid can cause immediate \_\_\_\_\_ on exposed skin.
- \_\_\_ 4. Odorized propane should be detectable to a person with a normal sense of smell at \_\_\_\_\_ of the lower flammability limit.
- \_\_\_ 5. Employees involved in evacuating the engine fuel tank should use the appropriate \_\_\_\_\_.
- \_\_\_ 6. All \_\_\_\_\_ must be kept away during propane tank venting procedures.
- \_\_\_ 7. Propane vapor is \_\_\_\_\_ if accidentally inhaled in small quantities.
- \_\_\_ 8. The document that provides propane chemical safety information for employees is the \_\_\_\_\_.

*Answers: 1-H, 2-F, 3-B, 4-C, 5-E, 6-A, 7-G, 8-D*

# ***Chapter Three***

## ***Pre-Conversion Inspection/Validation***

## CHAPTER 3: PRE-CONVERSION INSPECTION/ VALIDATION

### 3.1 Validating a Vehicle Prior to Conversion

Vehicles being considered for conversion to propane should be carefully screened to ensure satisfactory results. Not every vehicle can or should be converted. This pre-conversion checklist will help you decide whether a vehicle is a good candidate for conversion.

#### 3.1.1 Pre-Conversion Checklist

The customer should be advised that any defects in the vehicle should be remedied prior to conversion. A vehicle may be declined for conversion if the defects cannot be remedied. Customers sometimes mistakenly assume that:

- A used vehicle that has been converted to propane will be restored to like-new condition;
- Any and all existing vehicle defects will be repaired during the conversion;
- The conversion facility will repair any failure of any component after the vehicle is converted, even if the failure is not conversion-related.

A pre-conversion inspection should be performed on every candidate vehicle, including new vehicles, to avoid misunderstandings or wasting time and resources on a conversion that will not work out either short- or long-term.

#### 3.1.2 Converting High-Mileage Vehicles

The conversion facility should consider a thorough inspection of the engine and engine compartment, including any noises, leakage or smoke, before converting a vehicle that has accumulated more than about 60,000 miles.<sup>1</sup> An engine oil analysis is strongly recommended.

- A compression or leak-down test may be performed on high-mileage vehicles. Any compression reading that varies more than 15 percent from the highest reading should disqualify a vehicle from conversion. A wet and dry compression test may indicate where engine wear may be located.

<sup>1</sup> 60,000 miles is a rough guideline and may not reflect the actual condition of the candidate vehicle. Conversion facilities should adopt their own criteria for determining a high-mileage vehicle.



### **WARNING**

Performing a compression test on a high-mileage vehicle introduces the possibility of spark plugs breaking during removal, which will then require extensive repairs.

- Any vehicle that shows visible white, blue, or black smoke during starting should be disqualified from conversion. The exhaust tailpipe should not have any oily or moist dark soot or film inside the pipe. The tailpipe should be dry.
- Connect a diagnostic scan tool to the diagnostic connector port. Check and verify any current or pending diagnostic trouble codes (DTCs). Verify operation of the oxygen sensors, especially the post-catalyst sensor, to verify proper catalytic converter operation. Also inspect short-term fuel trim (STFT) and long-term fuel trim (LTFT) values. They should be near zero.
- Inspect the transmission. A transmission fluid analysis is strongly recommended. Transmission servicing or fluid changes should only be performed by a qualified transmission repair facility. If the transmission is leaking fluid at the input shaft or drive shaft seals, or if it shifts roughly, these conditions should be documented.
- Inspect the cooling system. Verify the condition of the radiator, all hoses, drive belts, coolant and coolant overflow bottles. Check for visible cooling system corrosion, and verify that the engine's cooling fans are operating and cycling properly.
- Inspect the exhaust system, including manifolds, exhaust pipes, catalytic converters, mufflers and tailpipes. Verify and document any exhaust-system modifications.
- Inspect brakes and record abnormal conditions including erratic braking, noise, and leaks.
- Inspect the driveline, especially noting any looseness, shaking or noise.

### **3.1.3 Pre-Conversion Test Drive**

- **Cold and hot temperature starting**

Cold temperature means at least four hours since the last restart.

Hot temperature means no more than 10 minutes since the last restart following full-temperature operation. If the vehicle has electric cooling fans, they should cycle at least once without the air conditioning being engaged. This verifies that the engine is at full operating temperature.

- **Idle test**

The vehicle should idle for at least 30 seconds, smoothly, in gear without any notable problems, including surging or dying. The vehicle should be capable of an extended idle without issue.

- **Firm acceleration**

From a steady idle, accelerate the vehicle to highway speeds (almost full throttle, avoid over-revving the engine). The engine should produce no noises or jerking. Noises may indicate engine wear or damage, while jerking may indicate ignition, fuel system or transmission problems.

- **Highway cruise**

This test should provide information on roadworthiness, tire balance or wheel and frame alignment, and cruise control, if equipped.

- **Firm braking**

At highway speeds, firmly depress the brake pedal to bring the vehicle to a full stop without locking the brakes or allowing the vehicle to get out of control. This tests the vehicle's ability to brake smoothly without unusual noise or brake pulsation.

- **Deceleration**

With a gentle "throttle off" coasting from highway cruise speeds to almost fully stopped, the engine should not hesitate and there should be no detectable or harsh transmission downshifts.

- **Slow-speed, simulating parking lot driving**

Allow the engine to idle in drive. Occasionally depress the throttle to reach speeds of no more than 5 miles per hour, and stop frequently.

Some of the items shown on this checklist may indicate that a vehicle has been modified outside of its original specifications or that additional equipment has been installed. The inspection should also attempt to identify any additional work or expense that will be required beyond a typical conversion, such as removing a tool box or vehicle bed, or performing an underbody or underhood cleanup or pressure wash.

All checklists should have a place for the customer to sign, to verify that the customer acknowledges any existing wear items and defects. The vehicle should not be converted without the customer's signature.



### 3.2 Vehicle Sign-In Form—All Vehicles

The first step is to clearly identify the vehicle in a sign-in form or work order. This document should include, as a minimum:

<b>Vehicle Owner</b>	This means the owner of the vehicle, not the driver. For example, use “South Central Utility District” or “City of Industry,” not “Michael Jones,” unless he is the owner of a private vehicle or fleet. If in doubt, use the name on the purchase order or contract.
<b>Vehicle Address</b>	May require two or more entries. The primary entry should be the billing address, or the address used on the purchase order or contract. The second address may be where the vehicle is based, e.g., a service center or utility district field office.
<b>Vehicle Make and Model</b>	This should clearly identify the make of vehicle, e.g., Chevrolet or Ford, and the model, e.g., C-1500 or F-150.
<b>Body Style</b>	This should identify the body type, e.g., king cab, super crew, extended cab, station wagon, SUV, CUV, cab and chassis.
<b>Vehicle License Number</b>	Print the license number of the vehicle. If the vehicle has not yet been issued permanent license plates, use the last 8 numbers of the VIN (see below). These numbers indicate the model year, place of manufacture, and a sequential number.
<b>VIN</b>	The manufacturer’s permanent vehicle identification number. If the manufacturer has two identification numbers (e.g., cab and chassis, with an added utility body), the primary identification number, usually the chassis number, should be used.
<b>Door Number (Fleet Vehicle ID Number)</b>	Record the number issued by the customer’s fleet to identify the vehicle, e.g., 011-G-413. There is no standard numbering sequence or numbering convention.
<b>Vehicle Mileage</b>	Record the actual odometer reading as shown on the dash. Some vehicles may indicate the vehicle mileage during the OBD-II test. The two numbers should match. Enter an additional odometer reading when the conversion is completed, to indicate how far the vehicle was driven during testing.
<b>Vehicle Color</b>	This is for ease of identification.

<p><b>Date</b></p>	<p>The date the vehicle enters the conversion facility. Note also:</p> <ul style="list-style-type: none"> <li><input type="checkbox"/> Date and time conversion started,</li> <li><input type="checkbox"/> Date and time conversion completed,</li> <li><input type="checkbox"/> Date and time conversion inspection is completed,</li> <li><input type="checkbox"/> Date and time customer is called for notification of completion, and</li> <li><input type="checkbox"/> Date and time customer accepts vehicle.</li> </ul> <p>The vehicle sign-in form should contain spaces to enter additional dates and times if the vehicle is delivered by a fleet transport carrier.</p>
<p><b>Gasoline Fuel Level</b></p>	<p>As a courtesy to the customer, this helps resolve any questions about the amount of fuel that was in the vehicle at the time of entry.</p>
<p><b>Customer Sign Off</b></p>	<p>This is where the customer acknowledges the vehicle's condition and releases the vehicle to the conversion center.</p>
<p><b>Comment Section</b></p>	<p>Allow sufficient space for follow-up calls, indicating times and dates. All forms should include a "comment" section.</p>

The above information can be useful in resolving any later disputes as well as warranty claims and service. The customer should receive a copy of the sign-in form.

### 3.2.1 Vehicle Checklist After Customer Sign-In

The checklist should include a thorough vehicle inspection, including all of the following points.

Photograph the vehicle, including the vehicle VIN tag. Photograph the vehicle from all four corners; verify that any identification markings (license plate, door ID number, etc.) are visible. Document any anomalies.

The conversion facility should inspect:

- All body panels for paint mismatch, which might indicate an accident repair;
- All body panels for dents, scratches, blemishes, or other defects;
- All front and rear windows and door glass for scratches;
- All doors for window operation;
- All doors for latch and locking operation;

- ❑ All interior lighting;
- ❑ All exterior lighting, including headlights, tail lights, turn or directional signals, license light, and all lenses;
- ❑ All warning devices, including horn, emergency flashers, siren or alarm, backup alarms or sensors;
- ❑ Interior controls, including steering, shifting, pedals, floor mats, any other modifications that might indicate altered wiring systems or other changes to the vehicle that may affect the conversion;
- ❑ Interior accessories, including:
  - Air conditioning,
  - Heating,
  - Radio or other entertainment features (CD, DVD, MP3, GPS, Nav-Con), and
  - Additional communications or emergency equipment;
- ❑ Interior for upholstery stains or other interior damage or imperfections;
- ❑ Tires for manufacturer name, depth, proper rating for the vehicle, plus inspect for different size tires or tire size not appropriate for the vehicle;
- ❑ Wheel covers, rims, or other wheel-related items;
- ❑ Ride height, measured at each wheel center, from the ground to the bottom lip of the wheel opening as measured at the vehicle axle centerline;
- ❑ Front grill guards or electric winches.
- ❑ **Engine and Driveline**
  - The engine must start immediately without any noise, smoke or delay not attributable to the original vehicle.
  - The transmission should engage immediately with no noise, leaks, or slippage.
  - Dash-mounted warning lights— identify and document oil pressure, charging system, and any body-related warning lights.

## ❑ **Under-Hood Modifications (Photo-Document)**

- Additional batteries
- Sirens
- Alarms
- Radio or other communication devices
- Emergency vehicle charging or cooling system modifications
- Customer-added performance or cosmetic changes or modifications

## ❑ **Trunk or Bed-Mounted Auxiliary Equipment (Photo-Document)**

Some of these items may require relocation or removal during the conversion process.

- Emergency equipment
- Communications equipment
- Tool boxes
- Overhead racks
- Truck bed cover or liner
- Generators, welders, or other semi-permanently mounted equipment

## ❑ **Electrical and emission system**

- Check and verify proper operation of the vehicle's charging system, including battery and alternator; document charging and static voltage.
- Perform an On-Board Vehicle Diagnostic Code test. Document and remedy any active or pending diagnostic trouble codes prior to conversion. A vehicle with an active DTC should not be converted.

When all items on the vehicle checklist are identified, and both the conversion facility and the customer accept the vehicle's condition and agree the vehicle should be converted to propane, the vehicle should be considered suitable for conversion and the process may begin.

**Review of Chapter 3**

**Directions:** Select from the list below the response that most correctly completes each of the following statements. Write the letter of your choice in the space provided.

- |                     |                                |
|---------------------|--------------------------------|
| A. inspected        | E. unrelated to the conversion |
| B. compression test | F. modifications and add-ons   |
| C. DTC              | G. engine oil analysis         |
| D. OBD-II           | H. photographing               |

- \_\_\_ 1. An \_\_\_\_\_ may be performed to verify the condition of a high-mileage engine.
- \_\_\_ 2. Propane fuel system equipment must be fully \_\_\_\_\_ compliant.
- \_\_\_ 3. Before a vehicle is converted to propane, it should be thoroughly \_\_\_\_\_ for accident damage or modifications.
- \_\_\_ 4. It is important to clearly establish with the vehicle's owner that a propane conversion does not include repairs to any item \_\_\_\_\_ that may fail after the conversion.
- \_\_\_ 5. A \_\_\_\_\_ may be performed before converting a high-mileage vehicle to propane.
- \_\_\_ 6. Before converting a vehicle to propane, any active \_\_\_\_\_ recorded while the vehicle operated on gasoline must be corrected.
- \_\_\_ 7. An important part of the pre-conversion inspection includes \_\_\_\_\_ the VIN tag, license plate, body parts and any anomalies.
- \_\_\_ 8. Any vehicle \_\_\_\_\_ should be documented with photographs, and this documentation should be retained with the pre-conversion inspection.

*Answers: 1-G, 2-D, 3-A, 4-E, 5-B, 6-C, 7-H, 8-F*





# **Chapter Four**

## **Tanks**



## CHAPTER 4: TANKS

Converting a vehicle to propane autogas will add parts to, and in some cases remove parts from, the original vehicle. It is critical that the technician performing the conversion understand the conversion process and the applicable safety codes and standards, and it is especially critical that the technician fully understand OBD-II diagnostics. It is helpful if the technician is familiar with vehicle's dynamics, e.g., engine and combustion operations, handling, center of gravity and roll centers.

During conversion, the vehicle's electrical system will be opened and interfaced. Direct wire-to-wire electrical connections will be made. The vehicle's cooling system will be accessed in many applications. Some fabrication or metal work will be required for the installation of the fuel tank, which may require some drilling of metal panels. The installation of remote filling adapters may require drilling of outside body panels.



### CAUTION

The technician should use appropriate personal protective equipment (PPE), e.g., safety glasses, gloves, ear or hearing protection, safety shoes, whenever air or electric tools are used.

### 4.1 Tanks and Tank Installations

In the U.S., all propane containers are classified as either ASME tanks or DOT cylinders.<sup>1</sup> ASME and DOT containers have different physical configurations and different end-use applications. They are not interchangeable and should not be adapted or modified for end-use applications they were not designed for. Only containers that have DOT or ASME certification may be installed legally on vehicles in the U.S.

This course considers only ASME tanks. DOT cylinders are mainly used for industrial and off-road applications such as forklifts, mowers, conveyor belts, floor buffers or scrubbers.

There are two types of tank installations:

- Open vehicle installation, where the tank is installed in the bed of a pickup truck, under a truck body, or on a school bus, or
- Enclosed vehicle installation, where the tank is installed inside a sedan, SUV or van.

<sup>1</sup> NFPA 58, 2008 ed., §11.3.1.1



Tanks are selected for a specific installation based on the propane fuel system type as specified by the conversion equipment manufacturer. Two types of tanks are currently in use:

- Vapor pressure type: Tanks that use propane's vapor pressure to push liquid fuel to the engine for conversion to vapor, for example, in a vapor fuel-injection system; and
- Integral pump type: Tanks that use an integral fuel pump to elevate output pressure as needed, for liquid propane fuel-injection systems.

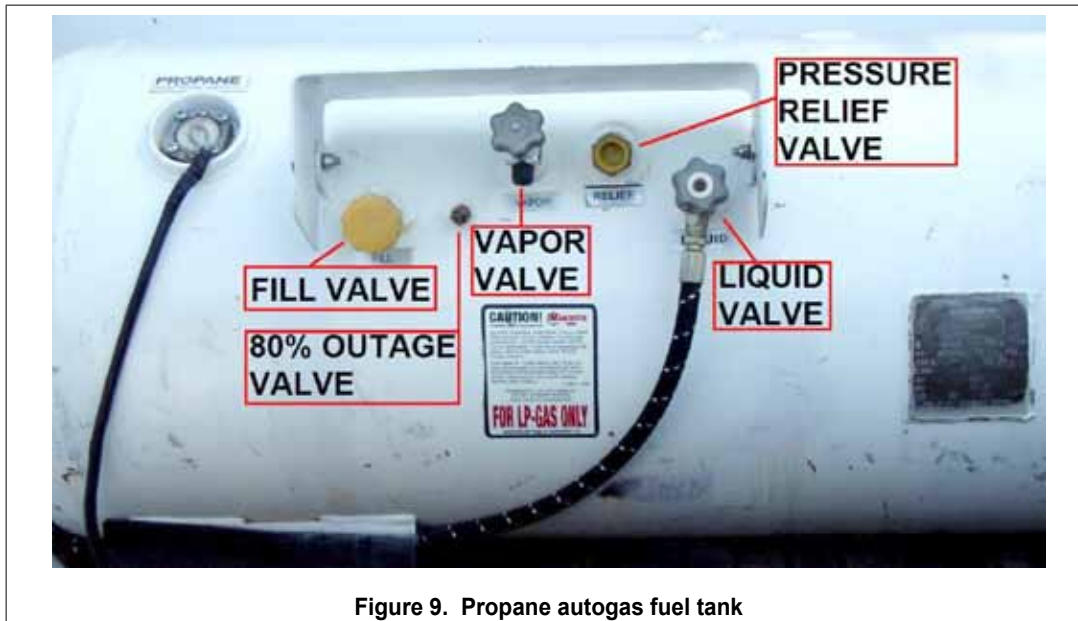

Figure 9. Propane autogas fuel tank

Figure 9 shows a traditional propane autogas fuel tank installed in the bed of a pickup truck. The tank is used in liquid service to supply fuel to a vapor fuel-injection system. See pp. 47-49 for tanks mounted within a vehicle.

Valves shown are as follows:

- Fill Valve. The valve used to fill the tank with liquid propane.
- 80 Percent Outage Valve (Fixed Maximum Liquid Level Gauge). This valve may be opened during filling to indicate when the tank is 80 percent full by releasing a thin stream of liquid propane.
- Vapor Service Valve. Used to purge vapor from the tank during the initial installation.
- Liquid Service Valve. Used to supply liquid propane to the engine.
- Pressure Relief Valve. Vents propane vapor if the pressure in the tank exceeds a preset value, typically 312 psig.



**Pressure Relief Valve**

**Manual Shutoff Valve**

**Liquid Service Valve Solenoid**

**Fill Valve Inlet**

**Fuel Return Line**

**Figure 10. LPI tank valves. The valves are located under the access plate. See Figure 11.**

These tank valves are typical of Roush CleanTech and CleanFUEL USA Liquid Propane Fuel Injection systems. The tanks are similar to vapor service tanks, except the fuel pump is located inside the tank. Access to the fuel pump is through a flanged “multi-valve” containing switches, sensors, solenoids, and manual service valves where applicable.



**Figure 11. LPI tank access plate**

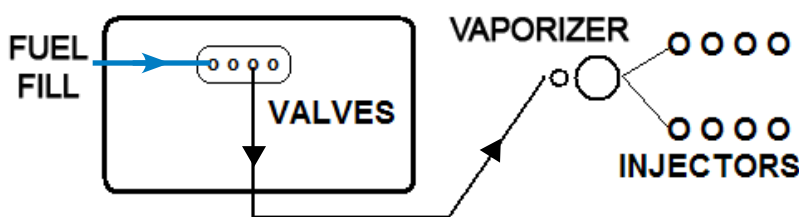

Figure 12. Vapor fuel injection system schematic

Vapor fuel injection systems use a conventional autogas tank with separate fill and service valves. The tank supplies propane liquid to a vaporizer, which changes the liquid to vapor and meters the vapor to the fuel injectors.

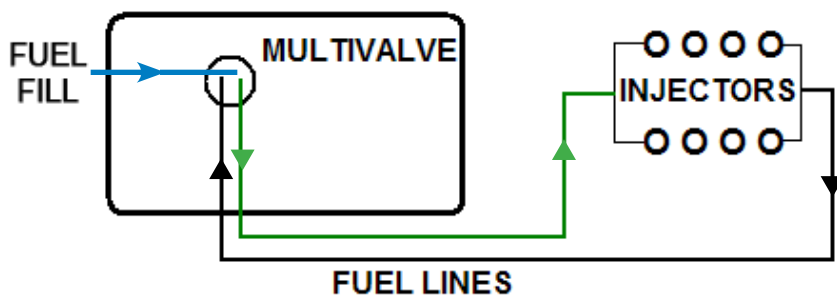

Figure 13. Liquid fuel injection schematic

Liquid fuel injection systems use a proprietary fuel tank with an integrated multivalve and an integrated fuel pump that supplies propane liquid to the injectors. Excess or partially vaporized fuel is returned to the tank.

#### 4.1.1 Open Vehicle Tank Installations

In an open vehicle installation, the tank is mounted in a pickup bed, under a flat or stake bed, or along the frame rails of a larger truck, i.e., in a location that exposes the tank to the outside air with no possibility of enclosure.

Although vehicles configured for mass transportation such as school buses, inter-city or metropolitan transit buses or shuttle buses are considered open vehicles, their tank installations may have additional requirements not applicable to a pickup or flatbed truck.

Taxicabs are not candidates for open vehicle tank installations, since the majority of the tanks are installed inside the trunk of the vehicle.

#### 4.1.2 ASME Tank Working Pressures

Before 2001, two different pressure ratings were allowed for ASME autogas tanks, based on a 1984 change in the applicable NFPA 58 standard:

- 250 psig maximum allowable working pressure, and
- 312.5 psig maximum allowable working pressure.

After 2001, the 250 psig fuel tank specification was dropped. Tanks produced after that date are rated for a maximum of 312 psig (the “312.5 psig” designation was also dropped). All 250 psig fuel tanks are rated for a safety factor of four times their design or service pressure, while 312 psig fuel tanks are rated for a safety factor of 3.5 times their design or service pressure.

Current U.S. standards specify that 312 psig is the maximum pressure rating.<sup>2</sup> Standards in other parts of the world specify a minimum pressure rating (e.g., 3000 kPa/435 psig).<sup>3</sup>

### 4.1.3 Enclosed Vehicle Installations

In an enclosed vehicle installation, the propane tank may be located inside the passenger compartment, including the trunk or the rear of an SUV or minivan. Since 1984 all tanks located inside a vehicle, and any tank located on a mass transportation vehicle, must be rated for 312 psig. A 312 psig tank may be used in any vehicle, in an open or closed location.

Tanks designed for enclosed installation provide for encasing the valves in a protective shroud or enclosure. The shroud allows any potential leaks from valves, hoses or fittings to be vented to the outside of the vehicle.<sup>4</sup>

A tank that was originally designed for a closed vehicle may be installed in an open vehicle, but a tank designed for an open vehicle may not be installed in a closed vehicle.

### 4.2 Tank Selection

Selecting an appropriately sized tank is critical. An oversize tank will add to the vehicle’s gross weight, alter its center of gravity and affect its towing and payload capacity.



#### **CAUTION**

Fuel containers are heavy and require the use of either a jack or lift to aid in the installation. Never attempt to lift a tank unassisted.

The capacity of an ASME tank is stated on the data plate in gallons of water capacity (gallons WC). Propane capacity is 80 percent of water capacity and may not be shown on the data plate.

<sup>2</sup> NFPA 58, 2008 ed., §11.3.2.1; NFPA 58, 2011 ed., §11.3.2.1

<sup>3</sup> ECE/324, EN-67, 2007 ed., §9.5

<sup>4</sup> NFPA 58, 2008 ed., §11.8.1.2 inclusive; NFPA 58, 2011 ed., §11.9.1.2 inclusive

### 4.2.1 Size Considerations

Historically, converters have tended to install the largest tank available, due to the lack of adequate refueling infrastructure and difficulty finding fuel on trips outside the vehicle's regular service area.

However, installing an oversize tank may alter the vehicle's GVW enough to put the vehicle in a higher weight classification and require a new emission certification. Installing an oversize tank may also impair the vehicle's performance, decrease the space available for cargo, or change how the vehicle handles during emergency maneuvers. For example, a tank placed behind the rear axle centerline may increase a vehicle's tendency to oversteer, i.e., to have the rear end swing out on turns.

Weight considerations are more important for bifuel (gasoline and propane) vehicles than for dedicated (propane-only) vehicles. Removing the gasoline tank for a dedicated conversion can offset the weight of the propane tank, since propane weighs about 2/3 as much as gasoline. Some upfitters, such as Roush CleanTech, size their tanks to match the vehicle's original weight classification and payload.

### 4.2.2 Range Considerations

Propane has about 75 percent of the energy (Btu content) of gasoline per liquid gallon, and it displaces about 4 to 5 percent of the air entering the engine. These factors combine to decrease miles per gallon in a converted vehicle.

For a sedan that has 14 gallons of gasoline storage on-board and a standard cruising range of 350 miles (at 25 mpg), the logical choice for a propane autogas tank would be at least 20-25 gallons. This would provide the same driving range as gasoline, which is important for a dedicated vehicle and a bonus for a bifuel vehicle.

Selection of a properly sized autogas tank for a bifuel application should be based on the vehicle's normal operating pattern. At a minimum, the propane tank should have at least the same relative storage capacity as gasoline, and within limitations, additional fuel storage based on the vehicle's fuel usage. This rationale changes if the vehicle is dedicated propane.

A 10-gallon autogas tank on a one-ton truck provides no realistic advantage, while a 40-gallon tank in a sedan (if it were possible) would prevent any possible passenger load and drastically affect the vehicle's performance.

A vehicle with a propane tank that provides 500 to 700 miles range places additional load on the vehicle's suspension and other body/chassis components.

### 4.2.3 Placement Considerations

Tank selection also depends on the tank's placement.

Underbody placements require careful consideration of the tank's proximity to moving suspension components, heat-producing components, and ground clearance (see sections 4.5 and 4.8).

- **Heat**

A propane autogas tank must be located at least 18 inches from any heat-producing component unless a non-combustible baffle (heat shield) is placed between the two.<sup>5</sup> Depending on the design of the heat shield or the location of the propane-carrying components, either the exhaust system or the fuel tank and fuel lines may be shielded.

Shielding may be fabricated from sheet metal, aluminum, stainless steel, composite metallic wrapping, or heat- and flame-resistant fabric.

- **Impact or Debris Protection**

Shielding to prevent gravel impacts under the vehicle or shielding to prevent impacts from unsecured cargo in the bed of a truck should be considered. This shielding may be fabricated from sheet metal, expanded metal, or steel plate. Access to the manual control valve and pressure release valve must not be impeded.

### 4.2.4 Tank Locations

Fuel containers may be located on, within or under a vehicle, with certain limitations (Figure 14). The basic requirements about side and ground clearance are well described in NFPA 58, Chapter 11.<sup>6</sup>

---

5 NFPA 58, 2008 ed., §11.7.1.3; NFPA 58, 2011 ed., §11.8.1.3

6 NFPA 58, 2008 ed., §11.7 inclusive; NFPA 58, 2011 ed., §11.8 inclusive

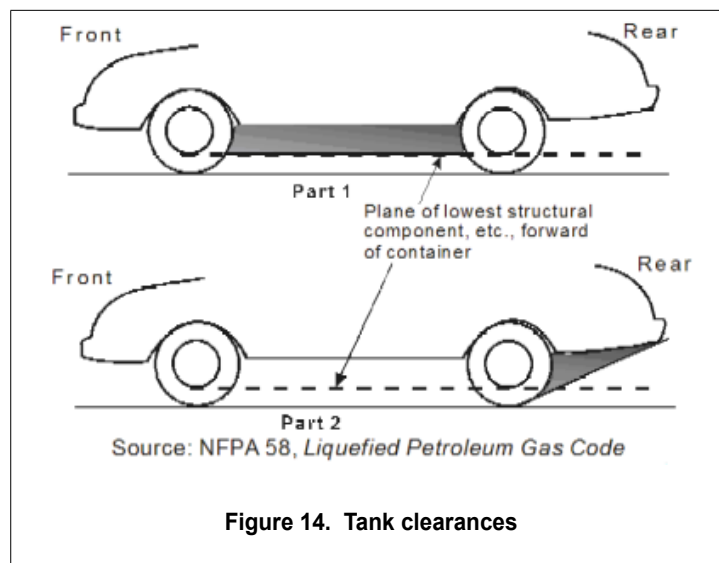

A critical and often overlooked factor in tank installation is the exit or departure angle. The tank and its appurtenances—valves, guards, fittings, and hoses—must not intrude into the shaded area behind the rear tires, from the centerline of the rear axle to the lowest permanent fixed part of the vehicle, including the bumper. This calculation should also be made with the vehicle at maximum carrying capacity, to place the suspension at its lowest level.

### 4.3 Purging

The fuel tank should be purged before it is installed or filled. Tank manufacturers often meter a small amount of nitrogen into the tank to pressurize the tank and prevent corrosion or rust. Through a series of five successive dilutions with propane vapor, purging removes this inert gas as well as any air and moisture that may have entered the tank if a valve has been opened between manufacture and installation. Purging the tank with propane vapor before introducing liquid also helps to maintain the proper level of odorant in the fuel.

A propane container that has not been properly purged of air will be difficult to fill to its proper filling level. More importantly, any air in the container will cause the pressure to spike, because air does not liquefy like propane vapor under pressure. A pressure spike could lead to the pressure relief valve venting a flammable mixture. In addition, air contains water vapor, which will be detrimental to the operation of the system.

The purging process is completed by charging the container with propane vapor, to ensure that the container will maintain a positive pressure and keep air and moisture from re-entering the tank.

### 4.3.1 Pressure Purge

ASME tanks are typically purged by pressure. Alternatively, they may be purged by vacuum (see Appendix D).

Pressure purging involves venting the contents of the tank to the atmosphere and feeding propane vapor from a fuel source into the tank. ASME tanks differ from stationary tanks and DOT fuel cylinders in that the fuel is withdrawn in liquid form, from a liquid withdrawal tube that extends to the bottom of the tank. Most DOT cylinders supply propane vapor from the top of the cylinder.

Opening the 80 percent outage valve will vent only a small amount of gas from the #54 drill size opening, rendering the outage valve ineffective during purging. The opening is too small to vent a significant volume of gas.



Figure 15. Vapor equalizing valve



Figure 16. Vapor service valve

To pressure-purge an ASME tank, install an equalizing valve<sup>7</sup> (Figure 15) or a vapor service valve (Figure 16).

Many ASME tanks have an unused vapor opening in the tank that must be plugged with a steel plug. This plug is removed and a vapor equalizing valve or a vapor service valve is installed after the tank is initially vented to atmospheric pressure. This process allows for purging after the tank is installed in a vehicle. This vapor purge valve communicates with a tube that extends to the top-inside of the tank. When a vapor return coupling is connected to this valve, it depresses an

<sup>7</sup> Some manufacturers call these valves “vapor return valves.”



internal plunger that opens the valve, allowing vapor to be withdrawn. After purging, the installed vapor equalizing valve or service valve remains attached to the vapor opening of the tank, and its outlet is sealed with a cap.

The tank is first allowed to vent to the atmosphere in a safe location, away from any ignition source.

Ideally, the purge valve would be vented to a capture tank or recovery vessel to retain any released hydrocarbon gases (“fugitive emissions”). Special equipment is required, including an apparatus to separate the purged tank contents from propane vapor.

The tank is typically purged before it is installed on a vehicle. A small amount of propane vapor<sup>8</sup> is fed into the tank. The fuel feed line is disconnected from the liquid withdrawal valve, and the tank is allowed to vent a mixture of propane vapor and air or propane vapor and inert gas through the liquid withdrawal valve. Air or inert gas will then be displaced when the valve is opened. This process should be repeated four times, for a total of five purgings. A final charge of propane vapor is then left in the tank to pressurize it and prevent the re-entry of air.

A temporary tee fitting and auxiliary control valves may be fabricated to aid in the pressure purging process. The purge pipe is a vertical pipe that has one 90-degree elbow at the top, with a nipple, and a second 90-degree elbow that directs the purged vapor 180 degrees from the pipe and keeps out rain or ice. The resulting purging stack must be electrically grounded.



### CAUTION

Pressure purging produces flammable propane-air mixtures that may be ignited by static electricity or another ignition source.

<sup>8</sup> If propane liquid is used, it may freeze any water or moisture-laden air in the tank, which would prevent the water or water vapor from being discharged from the tank.

**NOTE:** The liquid withdrawal valve, also called the manual service valve, may have an electrical solenoid (Figure 17) that controls the flow of propane when commanded by the driver or computer. If so, the solenoid must be energized to allow fuel to be withdrawn from the tank. Alternatively, the solenoid coil may be removed from the valve and the valve stem removed and disassembled. The valve stem is reassembled without the internal components, transforming the valve into a manual service valve. The valve is then controlled by the manual knob.

Reverse the procedure to reassemble the valve.



Figure 17. Electrically operated liquid service valve

#### 4.4 Installation Requirements and Options

A propane autogas tank must be attached to the vehicle using suitable fasteners that will not jar loose, slip or rotate. The fasteners must withstand without permanent deformation a static force applied in any direction equal to four times the weight of the container filled with fuel<sup>9</sup>.

For example, if a full tank weighs 350 lbs., then the tank installation must withstand a static force equal to four times that weight, 1,400 lbs., in six directions—up, down, left, right, front, rear—without slippage or deformation of the fasteners. Canadian code (B149.5) requires that all brackets have a minimum strength capable of retaining the tank at a force of 20 times the weight of the full container vertically, and 8 times the weight of the full tank in any direction horizontally.

Most propane autogas tanks manufactured in or supplied for North American use have mounting lugs or plates with pre-installed 1/2" NC weld-nuts. Many U.S. manufacturers and all European tanks have mounting lugs or plates with provisions for m10X1.25<sup>10</sup>, m12X1.50, or m14X2.0 metric fasteners. NFPA 58 does not specify the size, type or grade of fasteners, which leaves the decision to the installer or engineering team. Many installers use a 1/2" NC grade 5 or grade 8 bolt with suitable washers and a nut to retain the bolt.

9 NFPA 58, 2008 ed., §11.7.4.1; NFPA 58, 2011 ed., §11.8.4.1

10 Most fuel system components are designed and shipped with metric fasteners. These fasteners are specified "M" for metric, followed by the diameter and thread pitch in millimeters. For example, M10X1.50 designates a metric bolt, 10 mm in diameter, with a 1.50 mm thread pitch (i.e., distance between threads). The bolt head may be marked with tensile strength grades (8.8 or 10.9) that are equivalent to U.S. grade 5 or grade 8 bolts.

**OPTION 1**

Using a flat washer located under the fuel tank retaining bolt head and nut to reinforce the body or sheet metal is recommended. The material to which the tank is fastened often determines the type of retention hardware used. If the tank is mounted to a frame rail, a simple flat washer is all that is required. If the tank is mounted to sheet metal in the bed or trunk of a vehicle, a more robust means should be provided.

In Figure 18, the tank retaining bolt (1/2" x 5" NC Grade 8) passes through the bed and the reinforcing rib, then through the frame mount. This location replaces the original bed mounting bolt.

If other bolts pass directly through the vehicle bed, load-spreading fasteners should be used.



**Figure 18. Bed-mount installation that also serves as a tank mount**

**OPTION 2**

A flat plate is located under the retaining bolt heads or nuts. The location will dictate the actual size; 2" to 3" round or square plate steel is typical. The plate spreads the clamping force and distributes the load.



**Figure 19. Load-spreading washer located under vehicle bed**



**Figure 20. Load-spreading washer located under vehicle bed**

**OPTION 3**

This OEM application uses a frame-supported cradle that mounts through the bed.



Figure 21. OEM tank installation showing through-bed mounts



Figure 22. OEM tank installation showing through-bed mounts

The actual weight of the tank is placed directly on the frame, not on the bed of the truck.

**OPTION 4**

Some fuel tanks are secured to the vehicle using an engineered mounting system consisting of a support structure that is attached to the vehicle, with the fuel tank mounted to the structure, in the form of a large plate. The mounting plate may be isolated from the bed of the vehicle with vibration isolator pads.

An engineered mounting method uses the vehicle's original manufactured body or bed-retention system, or one that replicates the original vehicle manufacturer's fuel-tank mounting location. Some of these tank assemblies are mounted directly to the vehicle's frame, even though they are located in the bed, by means of connectors that pass through the bed, or to the vehicle's body using load-spreading support structures.



Figure 23. OEM engineered tank-mounting installation

The engineered mounting method often uses the OEM's vehicle crash-protection design, as required by the FMVSS for the OEM, not specifically for the conversion.

It is important to remember that any installation of an autogas tank should at least equal the original vehicle manufacturer's design standard.

### 4.4.1 Universal Installation (“Slick” Tank)

If an autogas tank is mounted with slip-fit brackets (commonly called a “universal” or a “slick” tank installation), it is recommended to use brackets designed and manufactured by the tank or vehicle manufacturer or authorized representative. The manufacturer of the bracket should be clearly identified by legible markings. It is strongly recommended that installers not fabricate tank-mounting brackets unless they are approved by the tank manufacturer.<sup>11</sup>

A weather-resistant insulator between the tank and the securing bracket should be installed to prevent abrasion, fretting, corrosion or rotation.

Some tanks mount directly to the vehicle frame, e.g., cab and chassis, school buses, and larger trucks. These tanks should use existing frame holes wherever possible. Chassis manufacturers do not recommend drilling additional holes in or welding brackets onto frame members.

<sup>11</sup> NFPA 58, 2008 ed., §11.7.4.1 outlines the requirements for fuel tank retention, including slippage or rotation. These design requirements may be outside the capability of the typical tank installer (NFPA 58, 2011 ed., §11.8.4.1)

#### 4.4.2 Tanks Located on the Vehicle

ASME tanks may be painted to match the vehicle's color. Light, heat-reflective colors are recommended.<sup>12</sup> Coatings must also protect against corrosion.<sup>13</sup> Any drilling or cutting that produces raw metal edges in a vehicle body or bed must be protected by a suitable anti-corrosion compound. These compounds are readily available at automotive supply outlets and automobile dealerships' parts departments.<sup>14</sup>

Figures 24 and 25 show autogas tanks installed in 1/2 - 3/4 ton trucks. The tanks were installed using conventional bolts against a load-spreading 3" plate or washer. The tanks are painted the same color as the vehicle.



Figure 24. Truck-mounted tank

This installation uses the tank manufacturer's mounting pads with various bolt locations that can be used for fasteners. This generic tank is not designed for a specific application and may be installed in any application that safely supports its filled weight.



Figure 25. Truck-mounted tank

<sup>12</sup> NFPA 58, 2008 ed., Appendix §A.6.6.1.4; NFPA 58, 2011 ed., Appendix §A.6.6.1.4

<sup>13</sup> NFPA 58, 2008 ed., §11.3.7; NFPA 58, 2011 ed., §11.3.7

<sup>14</sup> Roush CleanTech recommends Motorcraft® Premium Undercoating (PM-25-A).

### 4.4.3 Fuel Tanks Located Under the Vehicle

Fuel tanks located under the vehicle have unique positioning challenges and requirements. Among the most important of these is ground clearance, especially when the vehicle is fully loaded. Isolation from exhaust or other heat-producing components is also critical. Another factor is the “exit” angle when departing a steep drive.<sup>15</sup> If the tank is located behind the rear axle, it must be above a line drawn from the center of the rear axle at the point where the rear tire contacts the ground to the lowest fixed structural point of the vehicle,<sup>16</sup> usually the rear bumper. Locating the tank above this line keeps the tank from scraping the ground when exiting a driveway.

No added components should protrude below the areas shown in red. This red area indicates the lowest part of the vehicle, the front cross member and the rear axle, not including the differential.



Figure 26. No tank mounting below the shaded area

No components should protrude below the area at the rear of the vehicle shown in red, from the center of the rear tire where it contacts the ground to the lowest fixed structural part of the vehicle.



Figure 27. No tank mounting below the shaded area

If the tank is located closer than 18” to any heat-producing component (exhaust system, engine, transmission, air conditioning discharge), a non-combustible baffle or heat shield with an air gap on both sides must be positioned between them.<sup>17</sup> The chassis or frame may serve as the heat shield. Installers may add additional protection of the tank or tank valves as needed, as long as the tank’s valves and fittings remain accessible.

Any fuel-carrying component in close proximity to a heat-producing source should be protected from radiant heat by shielding or other insulation.

<sup>15</sup> NFPA 58, 2008 ed., §11.7.3 inclusive; NFPA 58, 2011 ed., §11.8.3 inclusive

<sup>16</sup> NFPA 58, 2008 ed., §11.7.3.6 (1) and (2); NFPA 58, 2011 ed., §11.8.3.6 (1) and (2)

<sup>17</sup> NFPA 58, 2008 ed., §11.7.1.3 ; NFPA 58, 2011 ed., §11.8.1.3

This twin manifold tank is located under the rear of a one-ton truck, where the second gasoline fuel tank was originally located. Note the shielding between the exhaust tailpipes and the rock guard protecting the tank's valves.



**Figure 28. Manifold tank installed behind the axle in the original tank location**

This underbody tank is located outside the frame rail on a one-ton truck. The placement of the exhaust catalyst prohibits the propane tank from being installed inside the frame rail.



**Figure 29. Tank installed between body side and frame rail**

This underbody tank is located under a truck inside the frame rail.



**Figure 30. Tank located inside the frame rail, opposite the exhaust catalyst**

This toroidal (donut-shaped) tank is located under the rear of a 3/4-ton truck, where the spare tire was located. This installation utilizes heat-reflective wrapping that shields the tank from the vehicle's exhaust tailpipe.

This type of tank is also available for interior mounting and is frequently installed in the spare tire location.



**Figure 31. Toroidal tank installed in spare tire location behind rear axle**



#### 4.4.4 Fuel Tanks Located Inside the Vehicle

Mounting and retention requirements for propane autogas tanks located inside vehicles differ from those for bed- or chassis-mounted tanks.

Fuel tanks located inside a vehicle must have a vapor-tight barrier or seal that keeps any leakage from valves or fittings from entering the passenger compartment.<sup>18</sup> The barrier or seal typically takes the form of a metal box or similar apparatus that fits around the valves and fittings on the tank. Access to the valves and fittings is gained by removing the vapor seal box access panel. Codes require that the valves be accessible without the use of tools.<sup>19</sup>

The vapor seal tank is designed by the manufacturer for that purpose. No recognized aftermarket resource exists to convert conventional external-mount propane tanks for installation inside a vehicle. Some manufacturers provide a vapor-seal box that may be added to a tank. In these cases, both the vapor seal enclosure and the tank are specially designed.

Tanks mounted inside the vehicle are required to be vented to the outside. All the valves and fittings are located inside the vapor seal box, and all related fuel lines must be routed through conduit or flexible tubing that is sealed to the tank box. In addition, the opposite end of the conduit tubing should be secured to the vehicle by a flange or other suitable fitting. This practice ensures an air-tight and gas-tight installation.

Figures 32 and 33 show trunk-mounted tanks with vapor seal box and vent hoses routed through the large vent hose or conduit tubing.



Figure 32. Trunk-mounted tank



Figure 33. Trunk-mounted tank

<sup>18</sup> NFPA 58, 2008 ed., §11.8; NFPA 58, 2011 ed., §11.9

<sup>19</sup> NFPA 58, 2008 ed., §11.7.4.3; NFPA 58, 2011 ed., §11.8.4.3



**Figure 34. Trunk-mounted tank**



**Figure 35. Hoses and vent line in vapor seal box after removing the cover shown in Figure 33.**

A suitably sized PVC male coupling with a locking nut and protective collar should be installed in the trunk or other location as needed for compliance with NFPA 58 requirements. The flexible conduit is fastened to this fitting with a worm-drive hose clamp.

The coupling is retained by the locking ring. The collar provides additional abrasion protection for hoses as they extend through the end of the coupling. The PVC threaded section may be shortened to allow the collar to provide the locking function.



**Figure 36. PVC Vent Hose Coupling**

An alternate method uses a suitably sized metal flange that is securely fastened to the trunk or other suitable location. The flange should be sealed with an appropriate sealer material. The flexible conduit is fastened to this flange with a worm-drive hose clamp.



**Figure 37. Metal Flange Coupling**

#### 4.4.5 Hose Routing

At least three fuel hoses are routed through the flexible conduit tubing:

- Engine-fuel hose, typically 5/16" i.d.,
- Fuel filling hose, typically 1/2" i.d., and
- Pressure relief valve vent hose, typically 5/8" i.d.

Wiring for the fuel level gauge sending unit and the electrically operated fuel shutoff valve will also be routed through the conduit.

The 80 percent fixed maximum liquid level gauge hose, if installed, may be routed to the remote fill location. This hose or fitting may be required in some jurisdictions or by contract, but is not required to comply with NFPA 58.<sup>20</sup>

Fuel tanks located inside the vehicle require a remote filling device and a fixed maximum liquid level gauge to be permanently installed to the outside of the vehicle.<sup>21</sup> For automobiles and service vans, this type of installation allows for the vehicle to be refueled without opening the trunk, removing any trunk contents, or opening the vapor seal of the tank.

#### **CAUTION**

The tank vapor seal cover should only be removed by an individual who is authorized to inspect or service any of the valves or other components. The cover should never be opened for any other reason except in an emergency when it becomes necessary to close the tank's manual shutoff valve.

#### 4.4.6 Other Tank Options

Although not common in the U.S., the in-trunk or underbody toroidal tank is popular in other parts of the world. This tank construction is robust, and its design allows it to be installed in areas previously not used for fuel storage. Toroidal tanks designed for interior installation have the valves and fittings sealed in a vapor seal section, which is then vented to the outside of the vehicle.

The tank's relatively small storage volume tends to limit its use to sedans and light-duty vehicles.

<sup>20</sup> NFPA 58, 2008 ed., §§ 11.4.1.5 and 11.4.1.15; NFPA 58, 2011 ed., §§11.4.1.5 and 11.4.1.16

<sup>21</sup> NFPA 58, 2008 ed., §11.8.1.4; NFPA 58, 2011 ed., §11.9.1.4



Figure 38. Toroidal tank



Figure 39. Toroidal tank

Conformable tanks may be manufactured to the specific dimensions of a vehicle and would ideally fit in the original gasoline fuel tank's location.

Fully metallic conformable tanks allow unique installations. The conformable tank is made from extruded sections that are then welded together.

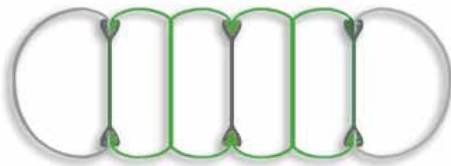

Figure 40. Conformable tank



Figure 41. Conformable tank

Note the vapor enclosure covering the valves and fittings.

A triple conformable tank installation on a large truck



Figure 42. Conformable tank

Underbody conformable tank installation



Figure 43. Conformable tank

## 4.5 Tank Installation Process

When a vehicle has been validated and approved for conversion and an appropriate fuel tank selected, the tank installation can begin.

Fuel tanks may be heavy and cumbersome. Lifting devices such as cranes or hoists should be used as needed, and safe lifting practices should be followed.

A fuel tank filled with propane to more than 5 percent full should not be transported or installed. The shifting weight when moving the tank may lead to injury. Most propane autogas tanks have a lifting lug welded to the tank body that provides a secure location when lifting with a hoist.

If the converted vehicle is to be dedicated propane, the gasoline tank and its related support brackets and fuel lines must be removed. Safe and careful handling of gasoline should be practiced. A gasoline tank may be heavy or unwieldy, especially if the tank still contains gasoline. A tank jack or modified transmission jack will assist in the removal process. Do not attempt to remove a gasoline tank without the aid of proper support devices or additional help.

Before drilling into any body or bed panel or in any frame section, ensure that there is sufficient clearance on the opposite side of the structure. Check and verify that the following are clear from possibility of damage during the drilling operation.

- Exhaust
- Chassis
- Original gasoline fuel tank
- Fuel lines
- Brake lines
- Electrical wiring or switches
- Spare tire
- Evaporative emission components

Repeated trial fittings will probably be required, especially if only one vehicle is being converted. If more than one vehicle is being converted with the identical vehicle and tank configuration, a drilling template may be made and used during the installations. If the tank will be installed inside the trunk of a sedan, additional trial fittings may be required.

### CAUTION

Safety glasses should be worn whenever working under a vehicle.

Store gasoline only in approved storage containers.

Fuel tanks usually provide at least four mounting points. Access to the two front mounting points may be difficult. For installations in a sedan, the rear seat may need to be removed to provide access. All four mounting points should be used unless the tank mounting is part of an engineered mounting system.

Other items such as sound-system components or the trunk-release mechanism may also need to be removed temporarily and later reinstalled or relocated.

Never permanently remove any OEM emission or safety equipment, including the inertia switch, air-bag sensor or any evaporative emission components unless specifically required by the fuel system manufacturer and the emissions certification.

When drilling through a body or trunk panel, remember that fuel tank retaining bolts, fuel lines or fuel-line fittings may be installed in those holes. When installed, these bolts, hoses, or fittings must not interfere with any suspension mount, gasoline tank mount, or exhaust pipe that may be located on the opposite side of the panel.

Self-locking nuts or split-lock washers that are removed should not be reused. The use of thread locking compound is strongly recommended when installing new hardware during final fit-up.

When fuel tanks are installed inside an enclosed vehicle, at least one suitably sized hole for vent-away hoses will be required. Additional holes may be required to provide routing for the vent hoses and fuel lines.

Holes should not be located in a wheel well or exposed to wheel spray or road debris. The exact location of a vent hole will depend on the application. Installing a mounting flange is recommended to provide a secure mounting location for the vent hose. This flange will be fastened over the vent hole that was previously drilled in the body panel.



**Figure 44. Drilling body panel for pass-through of hoses or fittings**

### 4.5.1 Underbody Access

Verify access and confirm there is no underbody interference with fuel and brake lines, exhaust components, related heat shielding or moving suspension parts.

Other than engineered tank mounting systems, propane fuel tanks traditionally use four mounting points.

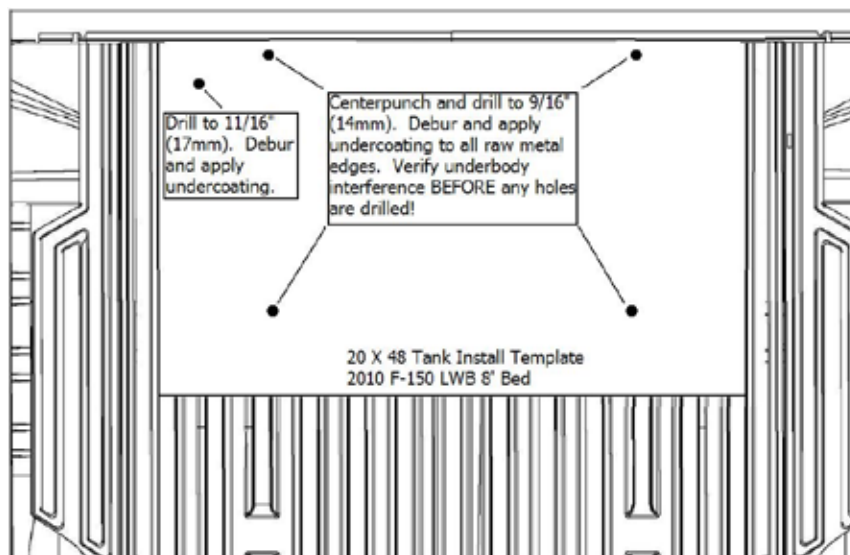

Figure 45. Tank installation template, showing locations for drilling

To ensure secure and safe retention of the fuel tank, it is critical to use all tank mounting bolts or bolt flanges.

The fuel tank may be temporarily installed to verify fit. The tank mounting flange holes are then marked for drilling. If a template is used, it should be identified by the vehicle make, model and model year, wheelbase, cab or bed length, tank manufacturer and tank size. The template will need to be modified if another manufacturer's tank is selected for installation.

Additional holes may be required for pass-through access for hoses and vent lines. Remember to de-burr any drilled metal and to protect all raw metal edges with anti-corrosion undercoating.

Whenever a fuel line passes through a frame or body panel, hose protection and strain relief should be provided. A bulkhead fitting is strongly recommended. If a bulkhead fitting is used, install and fully tighten the fitting at this time. (See Chapter 5 sections on fuel hoses and fittings).

Place the tank in the vehicle and install the retaining bolts, washers, locking nuts, reinforcing plates, and other structure or support adapters as required. Tighten the bolts and nuts to the appropriate torque. Do not allow the nuts to bottom on the unthreaded bolt shoulders.

#### 4.5.2 Nut and Bolt Torque

1/2" NC, grade 5 or grade 8, and 12mm to 14mm metric bolts or nuts should be torqued to not less than 50 lb. ft.

## Review of Chapter 4

**Directions:** Select from the list below the response that most correctly completes each of the following statements. Write the letter of your choice in the space provided.

- |                             |                                     |
|-----------------------------|-------------------------------------|
| A. 2001                     | F. NFPA 58                          |
| B. vapor seal cover         | G. ASME                             |
| C. purged                   | H. drilling                         |
| D. liquid propane injection | I. enclosed fuel tank installations |
| E. remote filling location  | J. 4 times                          |
|                             | K. 18 inches                        |

- \_\_\_ 1. Propane autogas tanks in \_\_\_\_\_ must have a Maximum Allowable Working Pressure (MAWP) of 312 psig.
- \_\_\_ 2. Tanks for \_\_\_\_\_ systems have a fuel pump inside the tank.
- \_\_\_ 3. Autogas tanks installed in the United States must be \_\_\_\_\_ tanks.
- \_\_\_ 4. Autogas tanks made after \_\_\_\_\_ must be 312 psig Maximum Allowable Working Pressure tanks.
- \_\_\_ 5. A \_\_\_\_\_ on a tank installed inside a vehicle must allow for access to an emergency shutoff valve without the use of tools.
- \_\_\_ 6. A propane autogas tank must be separated from a heat source (exhaust, transmission, etc.) by more than \_\_\_\_\_ or the tank must be shielded from the heat source.
- \_\_\_ 7. \_\_\_\_\_ allows underbody tank installations, if the tank meets specified ground clearance requirements.
- \_\_\_ 8. Before installation, a propane autogas tank should be \_\_\_\_\_ of air and/or inert gas.
- \_\_\_ 9. Although NFPA 58 does not specify the precise hardware requirements for mounting tanks, the code does require that fastenings withstand, without deformation, a force from any direction equal to \_\_\_\_\_ the weight of the filled tank.



- \_\_\_ 10. A \_\_\_\_\_ must be provided for a propane autogas tank mounted inside the vehicle.
- \_\_\_ 11. When \_\_\_\_\_ for a vent-away hose or tank mounting fasteners, care must exercised to avoid damaging fuel lines, brake lines, electrical wiring or exhaust system components.

*Answers: 1-I, 2-D, 3-G, 4-A, 5-B, 6-K, 7-F, 8-C, 9-I, 10-B, 11-H*





# **Chapter Five**

## **Fuel Transfer Lines**



## CHAPTER 5: FUEL TRANSFER LINES

### 5.1 Standards

Federal Motor Vehicle Safety Standards (FMVSS) for automobile manufacturers include standards for protecting fuel lines from impacts and preventing leaks.<sup>1</sup>

FMVSS standards do not dictate the actual routing or location of fuel lines. They require only that the lines survive vehicle impacts. It is the manufacturer's responsibility to demonstrate and verify the integrity of each line through engineering studies, computer simulations or crash testing. As a result of this testing, brake and gasoline fuel lines are routed in the most protective location on a vehicle. Accordingly, these locations should also be the locations of choice for routing propane autogas fuel lines.

“Piping” means any conduit that transports fuel from the storage tank to the engine. Piping may be rigid, semi-rigid, or flexible. Propane autogas hose must be rated for a minimum of 350 psig working pressure with a five times safety factor (5X), or a minimum 1,750 psig burst pressure. Each section of hose must be marked with “LP Gas, Propane, 350 psig Working Pressure” and the manufacturer's name or trademark.<sup>2</sup>

Assembled hoses with connectors must have a design working pressure of not less than 700 psig<sup>3</sup>. Hose assemblies must be tested at the time of installation at not less than the operating pressure of the system in which they are installed.<sup>4</sup>

If a hose assembly is pressure-tested, the test pressure must be 120 percent of the maximum working pressure (350 psig) of the hose, i.e., 420 psig.<sup>5</sup>

In the past, propane conversions in the U.S. typically used flexible rubberized stainless steel braid-reinforced LPG fuel hose (frequently called “QW” for “Quilt Wrap” hose). In the distant past, some conversions even used 3/8” copper tubing. The tubing and hoses were fabricated in the field by the installer. Hoses were cut to length with re-useable hose ends installed by either screw action or swaged fittings of various configurations. Joints in 3/8” copper tubing used flared tubing and fittings, typically SAE 45°.

Internationally, metal tubing with compression ferrule fitting ends is the standard fuel line of choice.

- 
- 1 FMVSS 501.301, fuel system integrity
  - 2 NFPA 58, 2008 ed., §5.9.6.4(A); NFPA 58, 2011 ed., §5.9.6.4(A) and (B)
  - 3 NFPA 58, 2008 ed., §5.9.6.4(B); NFPA 58, 2011 ed., §5.9.6.4(C)
  - 4 NFPA 58, 2008 ed., §5.9.6.4(D); NFPA 58, 2011 ed., §5.9.6.4(E)
  - 5 NFPA 58, 2008 ed., §5.9.6.4(C); NFPA 58, 2011 ed., §5.9.6.4(D)

Standard propane autogas hose has been shown to be slightly porous, allowing a small amount of propane to weep through the hose over time. Studies have shown that the rubberized inner lining may actually leach into the propane stream and that the inner lining may deteriorate over time, sending small rubber particles into the fuel filter and pressure regulator.<sup>6</sup>

### 5.2 Type III Hose

Many OEM's use Type III hose, also called "barrier hose." Type III hose has a nylon inner lining that resists seepage instead of a rubberized inner lining. Type III hose may be identified by its crimped-on hose ends, which differ from the screwed-on hose ends used with conventional fuel hose. Type III hose is often branded with the manufacturer's identification. If the hose cannot be permanently marked, it should be permanently identified with a metal tag or other means showing the date of assembly, the assembler's name or license number, and the certification proof pressure.

Type III hose also meets the CGA requirements that each hose must be fabricated by a certified hose manufacturer and each section must be pressure-tested and identified by a fabricator's certificate of test.

Type III hose tends to be less permeable than conventional hose. This feature is important during evaporative emissions testing, where any seepage through a hose wrapping is recorded. During this so-called SHED (for Sealed Housing for Evaporative Determination) test, the vehicle is placed inside an enclosed room and all fugitive emissions are recorded, including emissions from the vehicle's interior fabrics, the gasoline fuel tank, the tires, and in the case of propane fuel systems, any emissions from any released propane vapor, regardless of the source.

#### OPTION 1

"User-build" hose is acceptable to all jurisdictions in the U.S., but is seldom used in OEM applications and may not be approved for Canadian, European or Australian use. It is typically, but not always, identified by its quilt wrap with stainless steel reinforcement and rubberized inner lining.



Figure 46. User-build hose with swaged hose end



Figure 47. Section of standard #6 QW hose

## OPTION 2

Type III hose is preferred by the OEM's and most industrial forklift manufacturers. This hose typically has a rubberized outer cover with a stainless steel wire braid reinforcement over a nylon inner lining.



Figure 48. Type III hose

Type III hose, as required by code in Canada and used by U.S. OEM applications. It is seldom used in U.S. aftermarket conversions due to the additional cost and limited availability.



Figure 49. Type III hose

Composite hose with high-temperature silicone outer protective sleeve, installed at assembly. This hose will resist direct heat impingement from a flame or exhaust.



Figure 50. Composite hose

Composite hose with an abrasion-resistant outer covering, installed after assembly.



Figure 51. Composite hose

Stainless steel external braid nylon-lined flexible hoses allow for different tank configurations and a universal installation.

Stainless steel braid hoses are pre-fabricated by a certified hose manufacturer. Field repairs or modifications are not permitted.



Figure 52. Stainless steel braid hose

Rigid fuel lines do not seep, but special provision must be made to allow movement between fixed components by providing enough flexibility in the lines or a unique flexible joint. Rigid fuel lines should be protected against abrasion and road debris by a protective sheath, coating, or other abrasion-resistant protection.

### OPTION 3

These metal fuel lines represent current state-of-the-art technology. Both metal and composite hose/tube construction are currently used in OEM applications.

Metal fuel lines are typically pre-formed and are not adaptable to different vehicle applications. These fuel lines are custom-fabricated based on wheelbase, cab and bed length.

Note the flexible joint allowing some movement.



Figure 53. OEM metal fuel lines

### 5.3 Fuel Line Mounting and Routing

Fuel lines must be secured to prevent movement or vibration.

NFPA 58 provides basic performance requirements that are enforced by state or local authorities. This does not mean that other mounting and routing practices that can enhance security and longevity of an installation cannot be used, as long as they are approved by the authority having jurisdiction.

Chapter 11 of NFPA 58 has specific hose-location requirements covering, among other things, proximity to heat-producing components, wheel wells, and routing of lines through frame members or body panels.<sup>7</sup> Although NFPA 58 does not specify exact fuel line locations, fuel lines should not be routed in locations where they may become damaged due to body and frame movement, road debris, tire damage, service damage, under or over frame rails, or through frame rail openings where the fuel line may become damaged due to a “scissor” action.

Routing fuel lines inside a box-type enclosed frame rail is prohibited for safety reasons. Even though such routing would protect the line from impact, heat, abrasion, and other potential damage, it would also prevent leak testing and inspection and provide no opportunity to inspect the internal box frame location for sharp edges or pinch points.

OEM’s typically prefer to route fuel lines near the existing fuel and brake lines, as they tend to be well protected from impact. Installers at the OEM level have the advantage of selecting or

<sup>7</sup> NFPA 58, 2008 ed., §11.9 inclusive; NFPA 58, 2011 ed., §11.10 inclusive

fabricating fuel-line retaining brackets that replicate the mounting configuration of the gasoline and brake lines. Aftermarket installers may have to use other means of ensuring a secure fuel-line routing, but if at all possible, they should attempt to follow the OEM fuel-line locations.

Plastic zip-ties may be acceptable as long as the fuel line is securely fastened to a rigid body or chassis component and not fastened to an emergency brake cable, suspension component or axle. Zip-ties are available in several grades, colors, and heat- and UV-resistance ratings. If zip-ties are used, they should be rated for the highest heat and UV resistance available.

### OPTION 1

The plastic zip-tie is satisfactory for securing fuel lines, but may deteriorate with age and exposure to heat.

This installation shows a Type III stainless steel hose with a nylon inner core routed along with the original nylon gasoline fuel hose and existing wire harness.



Figure 54. Fuel line secured in original location by plastic zip-tie

Fuel-line routing and mounting should consider the movement, shifting and wear of body mounting pads and insulators as well as future vehicle maintenance and field service requirements that may place some fuel lines in a position where they may become damaged. Every effort should be made to standardize the fuel-line routing on identical vehicles, and if appropriate, to add additional heat shielding or clearances to prevent damage, rubbing or chafing.



**OPTION 2**

The Adel<sup>8</sup>-type clamp originated in the aviation industry. These clamps have rubber insulators around a metal band and are secured to a body or frame member by self-tap screws or click-type rivets.



Figure 55. Adel-type insulated clamp



Figure 56. Adel-type insulated clamp

An alternative is to position fuel lines in locations that would be used by the OEM if they were designing the fuel system, e.g., paralleling the positions of gasoline, diesel and brake lines and electrical cables. Fuel lines should not pass between body panels, under the frame rail, between the frame and body, or through a frame rail.

Figures 57 through 59 show how a vehicle's original fuel- and brake-line retaining clips and locations have been configured for propane autogas fuel lines, with additional OEM-quality retaining clips.

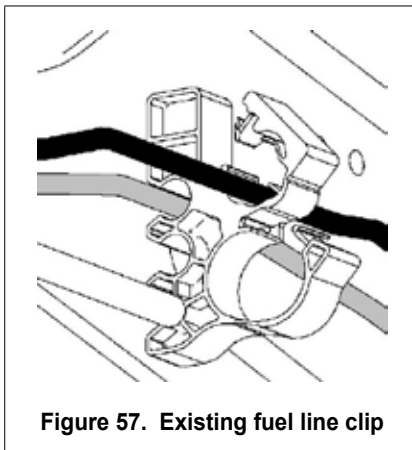

Figure 57. Existing fuel line clip

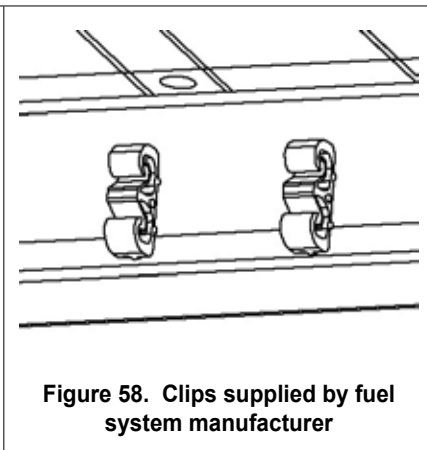

Figure 58. Clips supplied by fuel system manufacturer

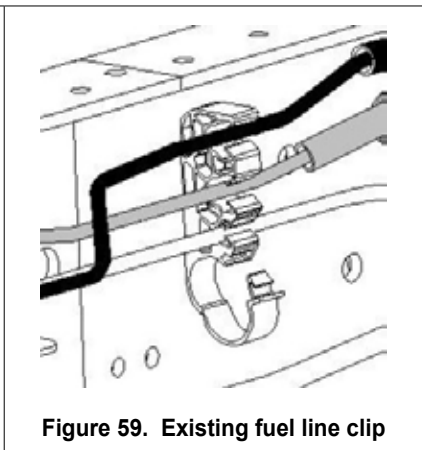

Figure 59. Existing fuel line clip

<sup>8</sup> “Adel clamp” has become a generic term for a rubber-coated metallic or plastic loop-type clamp designed to retain hoses or wire looms to another structure.

If a grommet is used to prevent abrasion damage to any hose, ensure that the grommet is sealed with a suitable adhesive material such as silicone or weather-stripping adhesive.

Another alternative is to use a bulkhead fitting where a fuel line must pass through a body panel, truck bed or frame rail. Although a grommet meets the base standards, it provides no positive anchor. A grommet will always shift or slip, placing the hose or fuel line directly against a metal body panel or frame member where the line may become damaged and eventually fail.

A bulkhead fitting serves as an anchor for the fuel line and prevents rubbing and abrasion.

The fitting shown at right allows for 3/8" SAE 45° flare fittings to be attached.



**Figure 60. Bulkhead fitting with 45° flare ends**

Review of Chapter 5

**Directions:** Select from the list below the response that most correctly completes each of the following statements. Write the letter of your choice in the space provided.

- |                             |                                  |
|-----------------------------|----------------------------------|
| A. 420 psig                 | E. field repairs or modification |
| B. bulkhead fitting         | F. secured                       |
| C. abrasion and road debris | G. 350 psig                      |
| D. 700 psig                 | H. Type III                      |
|                             | I. wheel wells                   |

- \_\_\_ 1. NFPA 58 requires autogas hose to be rated for a minimum of \_\_\_\_\_ working pressure.
- \_\_\_ 2. Assembled hoses with connectors must have a design working pressure of not less than \_\_\_\_\_.
- \_\_\_ 3. If a pressure test of a hose assembly is performed, the test must be at a minimum test pressure of \_\_\_\_\_.
- \_\_\_ 4. To achieve minimum fugitive emissions during EPA certification, some propane fuel-system OEMs use \_\_\_\_\_ hose and/or metal fuel lines.
- \_\_\_ 5. Stainless steel external braid hoses are pre-fabricated by a certified hose manufacturer, and \_\_\_\_\_ of them is prohibited.
- \_\_\_ 6. Rigid metal fuel lines should be protected against \_\_\_\_\_.
- \_\_\_ 7. Fuel lines must be \_\_\_\_\_ to prevent movement or vibration.
- \_\_\_ 8. Fuel lines must not be routed through \_\_\_\_\_.
- \_\_\_ 9. Where a fuel line must pass through a body panel, truck bed, or frame rail, a \_\_\_\_\_ should be used.

Answers: 1-G, 2-D, 3-A, 4-H, 5-E, 6-C, 7-F, 8-I, 9-B



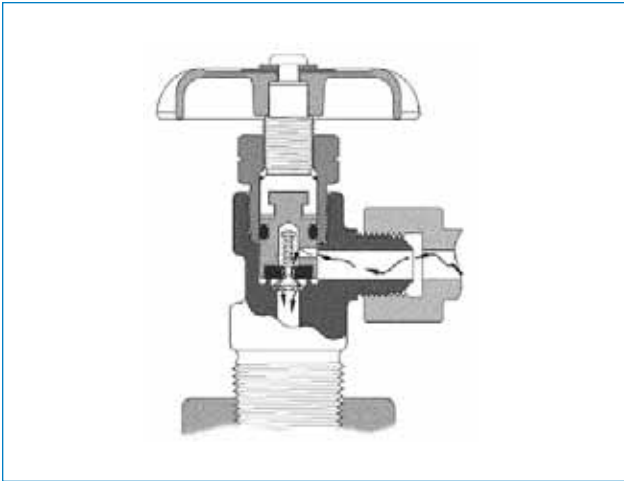
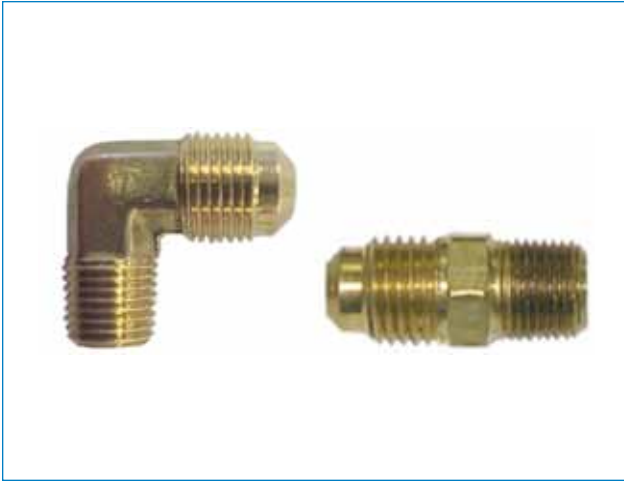

# ***Chapter Six***

## ***Fuel-Line Connectors***

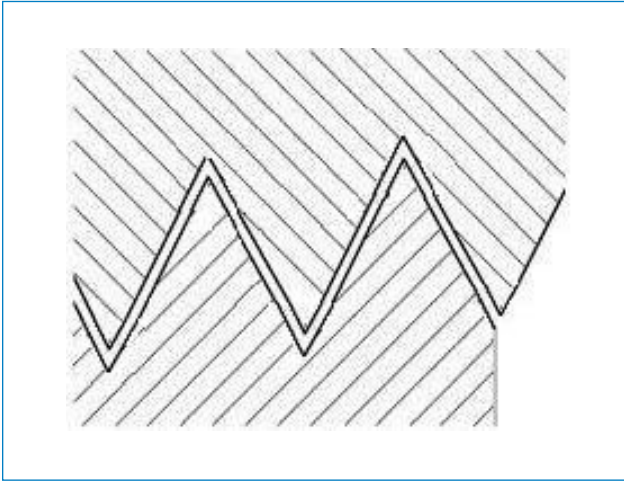

## CHAPTER 6: FUEL-LINE CONNECTORS

In North America, the SAE 45° flare fitting is the most common fitting connector used for couplings that may have to be removed for service. A tapered pipe thread is used for permanently installed fittings. Some OEMs elect to use a compression coupling, while others use a spring seal high-pressure fitting similar to an OEM gasoline or diesel fuel-filter fitting. The SAE 45° flare fitting may be reused indefinitely, as long as the mating surfaces are free from any defect from manufacturing or handling. Flare fittings may also be called “adapter couplings,” since most of them adapt a pipe-thread fitting to a flare fitting.

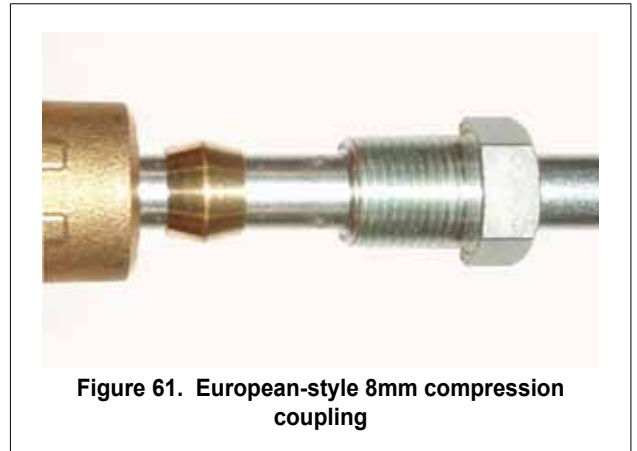

Figure 61. European-style 8mm compression coupling

Industrial and high-performance AN<sup>1</sup> 37° flare fittings with an appropriately rated engine-fuel hose may be acceptable, as long as there is no chance of cross-fitting the SAE 45° flare with the AN 37° flare fitting. These fittings are not compatible, and leakage will occur.

Many European installations currently use a single-ferrule compression fitting on a steel tube (6mm, 8mm or 10mm outside diameter, Figure 61). However, composite fuel lines using proprietary fittings are increasing in popularity.

U.S. and NFPA 58 standards do not specify which fuel-line connector must be used, only that they meet the required service pressure.<sup>2</sup>

### 6.1 Tapered Thread Fittings and Sealants

Thread taper specifications for National Pipe Thread (NPT)<sup>3</sup> fittings are shown in threads per inch, the amount of taper (degrees or inches per foot), and the angle or pitch of the threads. The basic design of the tapered pipe thread fitting, however, does not provide a positive torque value seal and is the most frequent source of leaks at fittings.

As the fitting is tightened, small voids will remain in the peaks and valleys of the threads. If not properly assembled, the joint will leak. Even if all necessary precautions are used, leaks can still occur at these joints.

<sup>1</sup> The abbreviation derives from an Army-Navy specification pre-dating WWII.

<sup>2</sup> NFPA 58, 2008 ed., §11.6.2.2 and §5.9.6.4(A-D); NFPA 58, 2011 ed., §11.7.2.2 and §5.9.6.4 (A-E)

<sup>3</sup> ANSI/ASME B1.20.1-1983 (R1992)

### National Pipe Thread

Figure 62 illustrates how the gap between the male and female threads can lead to leakage if a thread sealant is not used.

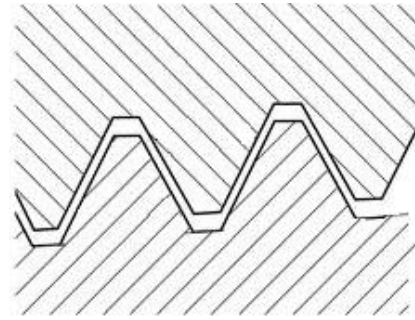

Figure 62. Thread gap

### National Gas-Pipe Thread (Dry-Seal Thread)

In Figure 63 the gap between the male and female threads is minimized. The thread will deform as it is tightened, as metal is forced into the peaks and valleys of the corresponding fittings. A thread-seal compound is still recommended for lubrication during assembly. Upon disassembly, the threads are usually damaged and may not reseal effectively if reassembled.

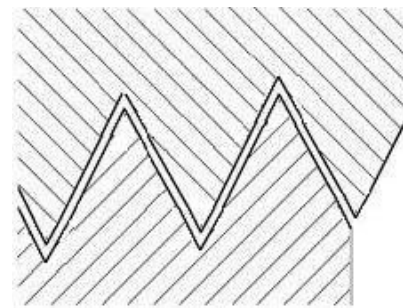

Figure 63. Minimized thread gap

As there is no positive stop when the tapered pipe thread fitting is fully assembled, the fitting is tightened using the installer's own "feel," which will change depending on the material used (brass, steel, stainless steel) and which thread-sealing compound is applied (sealant tape, liquid or paste thread seal, or an anaerobic thread seal, such as Loctite<sup>®</sup> 565, 567, 569, 592 or equivalent). Anaerobic thread sealer cures in the absence of air and serves as a thread lock.

Liquid, paste, or putty-type thread sealers fill the voids with a heavy paste compound that may be mixed with bulk fiber filler such as Rectorseal<sup>®</sup> 5 or Rectorseal<sup>®</sup> T plus 2 or Permatex<sup>®</sup> 14D<sup>4</sup> or equivalent.

Each of these sealing compounds has different lubricating qualities and bulk, and each of these characteristics alters the torque specification. These variations make consistently sealed fittings difficult to achieve. Caution should be observed when selecting a thread sealant. Tape-type thread sealants can leak if not installed properly. Some fuel-system suppliers will not honor a warranty if tape thread sealant is used.

Thread sealant should be installed on tapered male threads only, beginning approximately one turn from the end to prevent sealant compound from working into the component or fuel line. Follow the manufacturer's directions on using the sealant compound, or simply coat the threads with an even film. During assembly, some thread sealant will be forced out of the joint.

4 The trademarked names "Loctite," "Permatex" and "Rectorseal" are used for reference only.

Thread sealing compound should never be installed on flare threads or flare nut surfaces.

### Thread Sealant Alternatives

- OPTION 1**      Soft or medium setting fibrous filler
- OPTION 2**      Liquid or paste thread seal with PTFE (Teflon®) paste thread seal
- OPTION 3**      Anaerobic thread sealer/thread lock

### 6.2 Fuel Line Fittings

Some manufacturers specify and supply connectors with internal O-ring seals and spring lock retainer. These provide for quick assembly and limited rotational movement and are reusable without sealant, although special tools are required for disassembly.

Selecting the best type of fitting is a subjective judgment. Although all types mentioned in this book meet current standards, some offer additional service and ease-of-installation features.

#### OPTION 1

SAE 45° flare fittings incorporate a surface seal connection at the 45° flare face. The tube sealing surface must be concentric and absolutely free of burrs. Any scratches or surface irregularities will result in a leak.



Figure 64. SAE 45° flare fittings

#### OPTION 2

Roush CleanTech LPI fuel lines fit into a specially designed socket that uses O-rings to form the seal and prevent leakage. This formed fitting requires special tools to release the connection, but closely resembles a conventional gasoline or diesel fuel line fitting. This fitting allows for some rotation, which prevents stress on the fuel line and fitting.

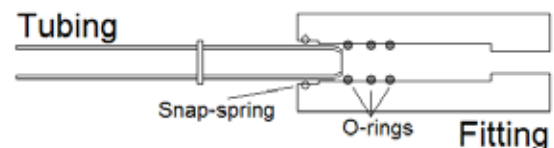

Figure 65. OEM high-pressure O-ring sealed fuel line fitting



### 6.3 Additional Fuel-Line Requirements

A hydrostatic pressure relief valve must be installed in each section of fuel line where propane can be isolated between positive closing shutoff valves.<sup>5</sup> When both the engine lockoff solenoid and the tank solenoid or manual shutoff valve are closed, liquid propane can become trapped in the line. To prevent damage to the fuel line due to a temperature increase and high pressure resulting from expanding propane,<sup>6</sup> the hydrostatic pressure relief valve will momentarily open to relieve the fuel-line pressure.

This valve should not be located under the hood where the released fuel may be drawn into the engine or exposed to exhaust-system heat. The recommended location is underbody, where the valve will discharge away from the vehicle and any other heat-producing components. No legal requirements dictate the location of the hydrostatic pressure relief valve, but the valve should be in a secure location that directs any potential discharge away from any heat source, including inside the engine compartment.

Some tanks' liquid service valves have an integrated hydrostatic pressure-relief valve. Some such valves are identified by the letter "H" in the valve model number. The integral hydrostatic valve (Figure 66, red arrow) allows excess pressure to return to the tank if the manual service valve is closed and there is excess pressure in the downstream line.

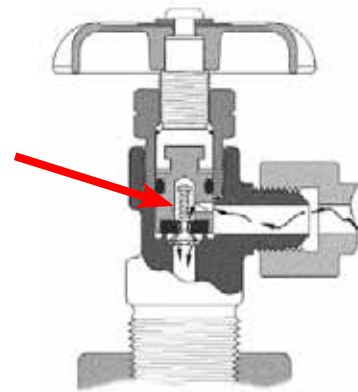

**Figure 66. Hydrostatic pressure relief valve.** These valves may be installed at the time of manufacture or field-retrofitted.

Some propane autogas systems do not use an external hydrostatic pressure relief valve. For example, the Roush CleanTech LPI and the CleanFUEL USA LPI fuel systems have a closed fuel circuit, so fuel is never fully isolated in a fuel line. These systems rely on the fuel-return line to vent excess pressure back to the tank.

All vapor fuel injection systems use a hydrostatic pressure-relief valve located somewhere in the liquid fuel supply line or the tank service valve. Conventional vapor injection applications allow for multiple fuel tanks to be used, since there is no fuel return line. Each tank must have a manual valve, or an electro-valve that provides for tank isolation. When multiple tanks are used, a hydrostatic check tee valve must also be installed, to prevent the exchange of fuel between tanks by pressure.

<sup>5</sup> NFPA 58, 2008 ed., §11.9.2 inclusive; NFPA 58, 2011 ed., §11.10.2 inclusive

<sup>6</sup> Propane liquid expands 1 percent for every 6°F rise above 60°F.

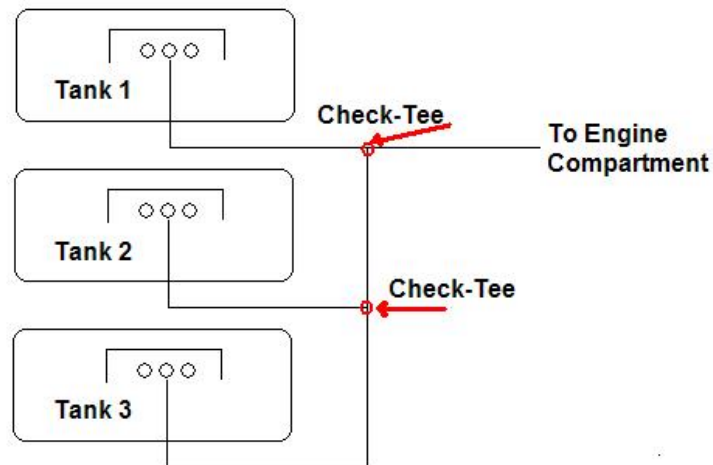

Figure 67. Multiple tanks configured for vapor fuel injection system

If two or more tanks supply fuel to an engine, a series of check valves must be incorporated to prevent cross-feeding of one tank to another, which could result in an overfill condition of one of the tanks. This “check-tee” incorporates a bulkhead fitting, two inlets with integral check valves, and a hydrostatic pressure relief valve.

Fuel will flow from the tank with the highest pressure (warmest tank) until the pressure is equalized.

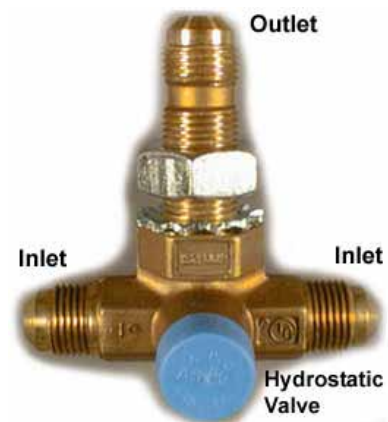

Figure 68. Check tee.

This valve has two inlets, one outlet, and one hydrostatic pressure relief valve.

Multiple tanks may be filled from one location, since each tank has a double back-flow check fill valve that also prevents tank cross-filling. In addition, each tank has an automatic stop-fill device that limits the amount of fuel in each tank to a maximum of 80 percent liquid fill.

### Review of Chapter 6

Directions: Select from the list below the response that most correctly completes each of the following statements. Write the letter of your choice in the space provided.

- |                                      |                               |
|--------------------------------------|-------------------------------|
| A. AN 37° flare                      | E. vapor injection systems    |
| B. hydrostatic pressure relief valve | F. SAE 45° flare              |
| C. check tee valve                   | G. single-ferrule compression |
| D. liquid propane injection systems  | H. thread sealant             |

- \_\_\_ 1. The most commonly used fitting connection in North America for fuel line couplings that may be removed for service is the \_\_\_\_\_ fitting.
- \_\_\_ 2. Care must be taken not to cross-fit connectors with SAE 45° flare fittings with \_\_\_\_\_ fittings.
- \_\_\_ 3. To prevent leakage in joints made with National Pipe Thread fittings, a \_\_\_\_\_ should be used.
- \_\_\_ 4. In each section of fuel line where propane can be isolated between positive closing shutoff valves, a \_\_\_\_\_ must be installed.
- \_\_\_ 5. Where more than one propane autogas tank is used in the installation, a \_\_\_\_\_ should be used to connect each tank fuel line to the fuel line supplying the engine.
- \_\_\_ 6. In some \_\_\_\_\_, a hydrostatic relief valve is not required in the fuel line because they are closed circuits that return to the fuel tank.
- \_\_\_ 7. Many European fuel lines use \_\_\_\_\_ fittings on steel tubing.

*Answers: 1-F, 2-A, 3-H, 4-B, 5-C, 6-D, 7-G*



# ***Appendices***

# APPENDIX A: MATERIAL SAFETY DATA SHEET

## Material Safety Data Sheet

### Odorized Propane

#### 1. CHEMICAL PRODUCT AND COMPANY IDENTIFICATION

**Product Name:** Odorized Commercial Propane  
**Chemical Name:** Propane  
**Chemical Family:** Hydrocarbon  
**Formula:** C<sub>3</sub>H<sub>8</sub>  
**Synonyms:** Dimethylmethane, LP-Gas, Liquefied Petroleum Gas (LPG), Propane, Propyl Hydride  
**Transportation Emergency No.:** 800/424-9300 (CHEMTRAC)

Material Safety Data Sheet – Odorized Propane			
<b>1. CHEMICAL PRODUCT AND COMPANY IDENTIFICATION</b>			
Product Name: Odorized Commercial Propane Chemical Name: Propane Chemical Family: Hydrocarbon Formula: C <sub>3</sub> H <sub>8</sub> Synonyms: Dimethylmethane, LP-Gas, Liquefied Petroleum Gas (LPG), Propane, Propyl Hydride			
Transportation Emergency No. 800/424-9300 (CHEMTRAC)		Emergency Number:	
<b>2. COMPOSITION/INFORMATION ON INGREDIENTS</b>			
INGREDIENT NAME / CAS NUMBER	PERCENTAGE	OSHA PEL	
Propane / 74-98-6	87.5-100	1000 ppm	
Ethane / 74-84-0	0-7.5		
Propylene / 115-07-1	0-10.0		
Butanes/ various	0-2.5		
Ethyl Mercaptan / 75-08-1	16-25 ppm	0.5 ppm	
<b>3. HAZARDS IDENTIFICATION</b>			
<b>EMERGENCY OVERVIEW</b>		<b>NFPA 704 Hazard Identification System</b>	
<p><b>DANGER!</b> Flammable liquefied gas under pressure. Move away from heat, sparks, flames, and all other ignition sources. Vapor replaces oxygen available for breathing and may cause suffocation in confined spaces. Use only with adequate ventilation. Odor may not provide adequate warning of potentially hazardous concentrations. Vapor is heavier than air. Liquid can cause freeze burn similar to frostbite. Do not get liquid in eyes, on skin, or on clothing. Avoid breathing of vapor. Keep container valve closed when not in use.</p>			
<b>POTENTIAL HEALTH EFFECTS INFORMATION</b>			
<b>ROUTES OF EXPOSURE:</b>			
Inhalation. Ingestion. It should be noted that before authorization could occur, the lower flammability limit of propane is			

#### 2. COMPOSITION/INFORMATION ON INGREDIENTS

INGREDIENT NAME / CAS NUMBER	PERCENTAGE	OSHA PEL
Propane / 74-98-6	87.5-100	
Ethane / 74-84-0	0-7.5	1000 ppm
Propylene / 115-07-1	0-10.0	
Butanes/ various	0-2.5	
Ethyl Mercaptan / 75-08-1	16-25 ppm	0.5 ppm

#### 3. HAZARDS IDENTIFICATION

##### EMERGENCY OVERVIEW - NFPA 704 - Hazard Identification System

**DANGER!** Flammable liquefied gas under pressure. Keep away from heat, sparks, flame, and all other ignition sources. Vapor replaces oxygen available for breathing and may cause suffocation in confined spaces. Use only with adequate ventilation. Odor may not provide adequate warning of potentially hazardous concentrations. Vapor is heavier than air. Liquid can cause freeze burn similar to frostbite. Do not get liquid in eyes, on skin, or on clothing. Avoid breathing of vapor. Keep container valve closed when not in use.



### POTENTIAL HEALTH EFFECTS INFORMATION

#### Routes of Exposure:

**Inhalation:** Asphyxiant. It should be noted that before suffocation could occur, the lower flammability limit of propane in air would be exceeded, possibly causing both an oxygen-deficient and explosive atmosphere. Exposure to concentrations >10% may cause dizziness. Exposure to atmospheres containing 8%-10% or less oxygen will bring about unconsciousness without warning, and so quickly that the individuals cannot help or protect themselves. Lack of sufficient oxygen may cause serious injury or death.

**Eye Contact:** Contact with liquid can cause freezing of tissue.

**Skin Contact:** Contact with liquid can cause frostbite.

**[Skin Absorption]:** None.

**[Ingestion]:** Liquid can cause freeze burn similar to frostbite. Ingestion not expected to occur in normal use.

**Chronic Effects:** None.

**Medical Conditions Aggravated by Overexposure:** None.

**Other Effects of Overexposure:** None.

**Carcinogenicity:** Propane is not listed by NTP, OSHA or IARC.

### 4. FIRST AID MEASURES

#### INHALATION:

Persons suffering from lack of oxygen should be removed to fresh air. If victim is not breathing, administer artificial respiration. If breathing is difficult, administer oxygen. Obtain prompt medical attention.

#### EYE CONTACT:

Contact with liquid can cause freezing of tissue. Gently flush eyes with lukewarm water. Obtain medical attention immediately.

#### SKIN CONTACT:

Contact with liquid can cause frostbite. Remove saturated clothes, shoes and jewelry. Immerse affected area in lukewarm water not exceeding 105°F. Keep immersed. Get prompt medical attention.

**INGESTION:** If swallowed, get immediate medical attention.

**NOTES TO PHYSICIAN:** None.

### 5. FIRE-FIGHTING MEASURES

**FLASH POINT:** -156°F (-104°C)

**AUTOIGNITION:** 842°F (432°C)

**IGNITION TEMPERATURE IN AIR:** 920-1120°F

**FLAMMABLE LIMITS IN AIR BY VOLUME:** Lower: 2.15% Upper: 9.6%

**EXTINGUISHING MEDIA:** Dry chemical, CO<sub>2</sub>, water spray or fog for surrounding area. Do not extinguish fire until propane source is shut off.

**SPECIAL FIRE-FIGHTING INSTRUCTIONS:** Evacuate personnel from danger area. Evacuated personnel should stay upwind, and away from tank ends, and move to a distance at least 1 mile or more away from containers subject to direct flame. Immediately cool container(s) (especially upper half) with water spray from maximum distance and the sides of containers, taking care not to extinguish flames. If flames are extinguished, explosive re-ignition may occur. Stop flow of gas, if possible without risk, while continuing cooling water spray.

**UNUSUAL FIRE AND EXPLOSION HAZARDS:** Propane is easily ignited. It is heavier than air; therefore, it can collect in low areas while dissipating. Vapors may be moved by wind or water spray. Vapors may move to areas where ignition sources are present and ignite, flashing back to the source. Pressure in a container can build up due to heat and container may rupture if pressure relief devices should fail to function.

**HAZARDOUS COMBUSTION PRODUCTS:** In typical use in properly adjusted and maintained gas appliances--None. If propane combustion is incomplete, poisonous carbon monoxide (CO) may be produced. Defective, improperly installed, adjusted, maintained, or improperly vented appliances may produce carbon monoxide or irritating aldehydes.

## 6. ACCIDENTAL RELEASE MEASURES

**STEPS TO BE TAKEN IF MATERIAL IS RELEASED OR SPILLED:** Evacuate the immediate area. Eliminate any possible sources of ignition and provide maximum ventilation. Shut off source of propane, if possible. If leaking from container or valve, contact your supplier and/or fire department.

## 7. HANDLING AND STORAGE

**HANDLING PRECAUTIONS:** Propane vapor is heavier than air and can collect in low areas that are without sufficient ventilation. Leak-check system with a leak detector or approved solution, never with flame. Make certain the container service valve is shut off prior to connecting or disconnecting. If container valve does not operate properly, discontinue use and contact supplier. Never insert an object (e.g., wrench, screwdriver, pry bar, etc.) into pressure relief valve or cylinder cap openings. Do not drop or abuse cylinder. Never strike an arc on a gas container or make a container part of an electrical circuit. See [Section] 16.

**OTHER INFORMATION** for additional precautions.

**STORAGE PRECAUTIONS:** Store in a safe, authorized location (outside, detached storage is preferred) with adequate ventilation. Specific requirements are listed in NFPA 58, *Liquefied Petroleum Gas Code*. Isolate from heat and ignition sources. Containers should never be allowed to reach temperature exceeding 125°F (52°C). Isolate from combustible materials. Provide separate storage locations for other compressed and flammable gases. Propane containers should be separated from oxygen cylinders, or other oxidizers, by a minimum distance of 20 feet, or by a barrier of non-combustible material at least 5 feet high, having a fire rating of at least 1 hour. Full and empty cylinders should be segregated. Store cylinders in upright position, or with pressure relief valve in



vapor space. Cylinders should be arranged so that pressure relief valves are not directed toward other cylinders. Do not drop or abuse cylinders. Keep container valve closed and plugged or capped when not in use. Install protective caps when cylinders are not connected for use. Empty containers retain some residue and should be treated as if they were full.

### 8. EXPOSURE CONTROLS/PERSONAL PROTECTION

#### ENGINEERING CONTROLS

##### Ventilation:

Provide ventilation so propane does not reach a flammable mixture.

##### Ignition Source Control:

Electrical wiring in liquid transfer areas must be Class I, Group D, and explosion-proof. Other possible ignition sources should be kept away from transfer areas. NO SMOKING signs should be posted at all approaches and entries to transfer areas. Transfer and storage areas must be kept free of flammables, combustibles and vegetation.

#### RESPIRATORY PROTECTION (SPECIFY TYPE)

**General Use:** None.

##### Emergency Use:

If concentrations are high enough to warrant supplied-air or self-contained breathing apparatus, then the atmosphere may be flammable (See Section 5). Appropriate precautions must be taken regarding flammability.

##### PROTECTIVE CLOTHING:

Avoid skin contact with liquid propane because of possibility of freeze burn. Wear gloves and protective clothing which are impervious to the product for the duration of the anticipated exposure.

##### EYE PROTECTION:

Safety glasses are recommended when filling and handling cylinders.

##### OTHER PROTECTIVE EQUIPMENT:

Safety shoes are recommended when handling cylinders.

### 9. EXPOSURE CONTROLS/PERSONAL PROTECTION

**BOILING POINT:** @ 14.7 psia = -44°F

**SPECIFIC GRAVITY (DENSITY) OF VAPOR (Air = 1) at 60°F:** 1.50

**SPECIFIC GRAVITY OF LIQUID (Water = 1) at 60°F:** 0.504

**VAPOR PRESSURE:** @ 70°F = 127 psig @ 105°F = 210 psig

**EXPANSION RATIO (from liquid to gas @ 14.7 psia):** 1 to 270

**SOLUBILITY IN WATER:** Slight, 0.1 to 1.0%

**APPEARANCE AND ODOR:** A colorless and tasteless gas at normal temperature and pressure. An odorant has been added to provide a strong unpleasant odor.

**ODORANT WARNING:** Odorant is added to aid in the detection of leaks. One common odorant is ethyl mercaptan, CAS No. 75-08-01. Odorant has a foul smell. The ability of people to detect odors varies widely. In addition, certain chemical reactions with material in the propane system, or fugitive

propane gas from underground leaks passing through certain soils can reduce the odor level. No odorant will be 100% effective in all circumstances. If odorant appears to be weak, notify propane supplier immediately.

## 10. STABILITY AND REACTIVITY

**STABILITY:** Stable.

**Conditions to avoid:** Keep away from high heat, strong oxidizing agents and sources of ignition.

### **REACTIVITY:**

**Hazardous Decomposition Products:** Products of combustion are fumes, smoke, carbon monoxide and aldehydes and other decomposition products. Incomplete combustion can cause carbon monoxide, a toxic gas, while burning or when used as an engine fuel.

**Hazardous polymerization:** Will not occur.

## 11. TOXICOLOGICAL INFORMATION

Propane is non-toxic and is a simple asphyxiant; however, it does have slight anesthetic properties and higher concentrations may cause dizziness.

**[IRRITANCY OF MATERIAL]:** None

**[SENSITIZATION TO MATERIAL]:** None

**[REPRODUCTIVE EFFECTS]:** None

**[TERATOGENICITY]:** None

**[MUTAGENICITY]:** None

**[SYNERGISTIC MATERIALS]:** None

## 12. ECOLOGICAL INFORMATION

No adverse ecological effects are expected. Propane does not contain any Class I or Class II ozone-depleting chemicals (40 CFR Part 82.) Propane is not listed as a marine pollutant by DOT (49 CFR Part 171).

## 13. DISPOSAL CONSIDERATIONS

### **WASTE DISPOSAL METHOD:**

Do not attempt to dispose of residual or unused product in the container. Return to supplier for safe disposal.

Residual product within process system may be burned at a controlled rate, if a suitable burning unit (flare stack) is available on site. This shall be done in accordance with federal, state and local regulations.

#### **14. TRANSPORTATION INFORMATION**

**DOT SHIPPING NAME:** Liquefied Petroleum Gas

**HAZARD CLASS:** 2.1 (Flammable Gas)

**IDENTIFICATION NUMBER:** UN 1075

**PRODUCT RQ:** None

**SHIPPING LABEL(S):** Flammable gas

**IMO SHIPPING NAME:** Propane

**PLACARD (When Required):** Flammable gas

**IMO IDENTIFICATION NUMBER:** UN 1978

**SPECIAL SHIPPING INFORMATION:**

Container should be transported in a secure, upright position in a well-ventilated vehicle.

#### **15. REGULATORY INFORMATION**

The following information concerns selected regulatory requirements potentially applicable to this product. Not all such requirements are identified. Users of this product are responsible for their own regulatory compliance on a federal, state [provincial] and local level.

##### **U.S. FEDERAL REGULATIONS:**

**EPA** - Environmental Protection Agency

**CERCLA** - Comprehensive Environmental Response, Compensation and Liability Act of 1980  
(40 CFR Parts 117 and 302):  
Reportable Quantity (RQ): None

**SARA** - Superfund Amendment and Reauthorization Act

- **SECTIONS 302/304:** Require emergency planning on threshold planning quantities (TPQ) and release reporting on reportable quantities (RQ) of EPA extremely hazardous substances (40 CFR Part 355).

Extremely Hazardous Substances: None

Threshold Planning Quantity (TPQ): None

- **SECTIONS 311/312:** Require submission of material safety data sheets (MSDSs) and chemical inventory reporting with identification of EPA-defined hazard classes (40 CFR Part 370). The hazard classes for this product are:

IMMEDIATE: Yes

PRESSURE: Yes

DELAYED: No

REACTIVITY: No

FLAMMABLE: Yes

- **SECTION 313:** Requires submission of annual reports of release of toxic chemicals that appear in 40 CFR Part 372.

Propane does not require reporting under Section 313.

#### 40 CFR PART 68 Risk Management for Chemical Accidental Release

**TSCA** - Toxic Substance Control Act

Propane is not listed on the TSCA inventory.

**OSHA** - Occupational Safety and Health Administration

29 CFR 1910.119: Process Safety Management of Highly Hazardous Chemicals.

**FDA** - Food and Drug Administration

**21 CFR 184.1655:** Generally recognized as safe (GRAS) as a direct human food ingredient when used as a propellant, aerating agent and gas.

## 16. OTHER INFORMATION

**SPECIAL PRECAUTIONS:** Use piping and equipment adequately designed to withstand pressures to be encountered.

NFPA 58 *Liquefied Petroleum Gas Code* and OSHA 29 CFR 1910.110 require that all persons employed in handling LP-gases be trained in proper handling and operating procedures, which the employer shall document. Contact your propane supplier to arrange for the required training. Allow only trained and qualified persons to install and service propane containers and systems.

**WARNING:** Be aware that with odorized propane, the intensity of ethyl mercaptan stench (its Odor) may fade due to chemical oxidation (in the presence of rust, air or moisture), adsorption or absorption. Some people have nasal perception problems and may not be able to smell the ethyl mercaptan stench. Leaking propane from underground lines may lose its odor as it passes through certain soils. While ethyl mercaptan may not impart the warning of the presence of propane in every instance, it is generally effective in a majority of situations. Familiarize yourself, your employees and customers with this warning and other facts associated with the so-called odor-fade phenomenon. If you do not already know all the facts, contact your propane supplier for more information about odor, electronic gas alarms and other safety considerations associated with the handling, storage and use of propane.

Issue Date: November, 2001

#### ISSUE INFORMATION

This material safety data sheet and the information it contains is offered to you in good faith as accurate. Much of the information contained in this data sheet was received from outside sources. To the best of our knowledge this information is accurate, but the Propane Education and Research Council does not guarantee its accuracy or completeness. Health and safety precautions in this data sheet may not be adequate for all individuals and/or situations. It is the user's obligation to evaluate and use this product safely, comply with all applicable laws and regulations and to assume the risks involved in the use of this product.

## **Appendix A: Material Safety Data Sheet**

NO WARRANTY OF MERCHANTABILITY, FITNESS FOR ANY PARTICULAR PURPOSES, OR ANY OTHER WARRANTY IS EXPRESSED OR IS TO BE IMPLIED REGARDING THE ACCURACY OR COMPLETENESS OF THIS INFORMATION, THE RESULTS TO BE OBTAINED FROM THE USE OF THIS INFORMATION OR THE PRODUCT, THE SAFETY OF THIS PRODUCT, OR THE HAZARDS RELATED TO ITS USE.

*The purpose of this MSDS is to set forth general safety information and warnings related to the use of propane. It is not intended to be an exhaustive treatment of the subject, and should not be interpreted as precluding other authoritative information or safety procedures which would enhance safe LP-gas storage, handling or use. Issuance of this MSDS is not intended nor should it be construed as an undertaking to perform services on behalf of any party either for their protection or for the protection of third parties. The Propane Education and Research Council assumes no liability for reliance on the contents of this material safety data sheet.*

## APPENDIX B: ON-BOARD DIAGNOSTICS

### OBD-I and OBD-II

During the mid 1970s, EPA required automobile manufacturers to comply with ever-tightening emission requirements. Early measures to lock in the engine air-fuel mixtures and ignition timing were easily circumvented, resulting in increased emissions.

In 1980, General Motors, Ford and Chrysler introduced electronic engine control systems. In 1988, fuel injection became standard for almost all U.S.-manufactured vehicles, and with it came the next generation of electronic engine controls, often called OBD-1 (On-Board Diagnostics, First Generation).

#### **On-Board Diagnostics: First Generation (OBD-1)**

Beginning in 1988, the California Air Resources Board, and later the U.S. Environmental Protection Agency, required vehicle manufacturers to include in their on-board computers a self-diagnostic program that could identify emissions-related faults.

OBD-1 is a set of self-testing and diagnostic instructions programmed into the vehicle's on-board computer. The programs are designed to detect failures in the sensors, actuators, switches and wiring of the vehicle's emissions-related systems. If the computer detects a failure in any of these components or systems, an indicator on the dashboard illuminates to alert the driver. The indicator is illuminated only when an emissions-related problem is detected.

OBD-1 systems detected only failed components. Degraded components would not set codes unless the near failure of the component resulted in an emission fault (oxygen sensor, MAP sensor, TPS sensors showing no output when compared against other sensor values).

The computer also assigned a manufacturer-specific numeric code for each problem that it detected and stored these codes in its memory for later retrieval. These codes can be retrieved from the computer's memory with the use of a "Code Reader" or a "Scan Tool." All manufacturers had different scan tools, with different diagnostic protocols and different criteria for diagnostic faults.

With the exception of some 1994 and 1995 vehicles, which had an early version of OBD-2, most vehicles from 1982 to 1995 are equipped with some type of OBD-1 diagnostics.

#### **On-Board Diagnostics: Second Generation (OBD-2)**

OBD-2 is an enhancement of OBD-1.

In addition to performing all the functions of the OBD-1 system, the OBD-2 system has been enhanced with new diagnostic programs. These programs closely monitor the functions of various emissions-related components and systems as well as other systems, and they make this information readily available to a properly equipped technician for evaluation.

Some emissions problems related to degraded components occur only when the vehicle is being driven under a load. Emissions checks at the time were not performed under simulated driving conditions. As a result, many vehicles with degraded components were passing emissions inspections.

Codes, code definitions, diagnostic connectors, communication protocols and emissions terminology were different for each manufacturer. This caused confusion for the technicians working on different make and model vehicles.

To address these problems, CARB and EPA enacted new, standardized regulations. The regulations required vehicle manufacturers to equip their new vehicles with devices capable of meeting all of the new emissions standards and regulations. The result was “On-Board Diagnostics, Second Generation” (OBD-2).

The main objectives of OBD-2 are:

- To use a standardized Assembly Line Diagnostic Link (ALDL) in all vehicles. Before OBD-2, ALDL connectors were of different shapes, locations, and sizes.
- To standardize communication procedures and protocols between the diagnostic equipment (scan tools, code readers, etc.) and the vehicle’s on-board computer.
- To standardize the code numbers, code definitions and language used to describe faults. Before OBD-2, each vehicle manufacturer used its own code numbers, ALDL connector, code definitions and language to describe the same faults. This standardization was referred to as the SAE-J-1939 Standard.
- To expand emissions-related system monitoring. This includes a set of computer-run diagnostics called “monitors” that continuously perform diagnostics and testing to verify that all emissions-related components and/or systems are operating correctly and within the manufacturer’s specifications.
- To detect degraded and/or failed emissions-related components or systems that could cause tailpipe emissions to exceed by 1.5 times the Federal Test Procedure (FTP) standard.
- To expand the operation of the malfunction indicator lamp (MIL) and command the MIL “on” when tailpipe emissions exceed the FTP standard by 1.5 times.

## APPENDIX C: PRE-CONVERSION GUIDELINES

The following questionnaire provides additional information to help converters judge whether a vehicle is a good candidate for conversion.

### Current or Pending EPA or CARB Emission Certification

- Is there a currently EPA- or CARB-certified retrofit fuel system for the vehicle or engine group to be converted?
- Will the fuel system proposed to be installed on this vehicle be EPA- or CARB-certified by the time the conversion is completed?
- Is the vehicle's certification valid in the jurisdiction where it will operate? Vehicles registered in a U.S. jurisdiction, such as California, that has adopted CARB emissions standards must be CARB-certified. An EPA certificate of conformity by itself is not sufficient in these jurisdictions.

If the answer to any of these certification questions is no, the vehicle cannot be legally converted to propane. Some exceptions exist, which include:

- Emergency vehicles.
- A non-certified vehicle may be driven immediately after conversion to accumulate testing data and mileage prior to emission certification.
- A non-certified vehicle may be driven by the original equipment manufacturer during the testing and qualification phases of development.
- A vehicle that is outside its useful life, usually 10 or more years old and with more than 120,000 accumulated miles, may be converted if it meets the conditions set out in EPA's guidelines. Some exemptions may apply to vehicles that are older than 10 years but are still OBD-II (1996 and newer) functional. For details, consult EPA's web site at <http://www.epa.gov/oms/consumer/fuels/altfuels/altfuels.htm>.

The equipment being considered for installation must be fully OBD-II compliant, and the vehicle's original On-Board Diagnostic (OBD) functions may not be disabled or defaulted unless approved by EPA or CARB emission filings.

### Current or Proposed Vehicle Use

Vehicles being considered for conversion should have a cost-recovery plan in effect. The cost of conversion should be weighed against the cost or relative vehicle value at the time of conversion and at the end of the vehicle's useful life. The decision to convert a vehicle based on cost alone rests upon the vehicle owner after he or she has been fully advised and made aware of any possible future cost-recovery values.



### Fuel Usage Based on Miles Driven Per Day or Week

Vehicles that do not accumulate many miles of operation may not recover the cost of the conversion. There is no hard and fast rule for calculating this cost-recovery period. This is a subjective decision made by the customer aided by the conversion facility.

### Intended Use

Vehicles that use substantial amounts of fuel may be good candidates for conversion. These vehicles include, but are not limited to, medium- and heavy-duty trucks, buses, vans and delivery vehicles.

- Light-duty vehicles used for long commutes, taxicabs, shuttles, courier and delivery functions and law enforcement are generally high-fuel-use vehicles.
- Emergency and custom-body vehicles such as ambulances and EMS trucks may not be the best candidates for conversions, due to a lack of available space.
- Micro, hybrid, and high-mpg vehicles typically have a limited ability to recover the cost of conversion. These vehicles may also exhibit a wide disparity in their cost of operation on propane compared to gasoline.

### Age and Condition

A vehicle's useful life depends on several factors:

- **Its current mileage:** The vehicle may have high mileage but be in excellent condition with a good, solid maintenance and repair history.
- **Its current condition:** The vehicle may be fairly new but severely overused for its current designation. Conversely, the vehicle may be fairly old but in excellent condition.
- **Its planned retirement date:** If the vehicle is nearing its planned retirement date, there may not be enough cost recovery time remaining to justify conversion.
- **Its current cost/life ratio:** This is a subjective value. A vehicle, which has had a high cost repair history, may not be a good candidate for conversion, even if it is relatively young in its fleet life.

### Additional Considerations

- The current and estimated cost of gasoline and propane
- Vehicle's current or estimated miles per gallon

Fuel cost per mile is the most valuable factor to determine the cost recovery of a conversion over a vehicle's useful life:

- A vehicle that achieves 20 mpg on gasoline at \$3.50 per gasoline gallon will cost 17.5 cents per mile.
- A vehicle that achieves 15 mpg on propane at \$2.65 per propane gallon will also cost 17.5 cents per mile.
- The actual fuel end-cost should be used to compare “apples to apples” when considering the value of rebates, tax credits and other incentives.

### **Post-Conversion Success**

The overall conversion should complement the vehicle, not diminish its usefulness. Installing tanks that are either too large or too small will affect the vehicle's usefulness.

A carefully designed, well-executed conversion will increase the user's acceptance of the converted vehicle and encourage further use of propane. A carefully designed, well-executed conversion will generally increase the vehicle's resale value.

## APPENDIX D: PURGING PROPANE AUTOGAS TANKS WITH A VACUUM PUMP

### Vacuum Purge

A vacuum purge uses a vacuum pump to draw the remaining contents from the tank. The vacuum pump is allowed to remain connected to the tank until a steady vacuum of at least 27 inches of mercury (in/Hg) is achieved. The tank should be allowed to remain at this level of vacuum for at least 15 minutes (there is no standard for time), to ensure that any remaining air and moisture are allowed to vaporize and dissipate.

When the vacuum purge time has elapsed, the tank valves must be closed until liquid propane is placed in the tank. If any valve is opened inadvertently, the tank must be re-purged.



### EXPLOSION HAZARD

A vacuum purge should never be used if the tank has ever contained fuel.

## APPENDIX E: GLOSSARY

Some of the terms used in this module are defined in National Fire Protection Association (NFPA) Pamphlet 58, *Liquefied Petroleum Gas Code*. The list below is not exhaustive. Its purpose is to explain terms commonly used in this manual and in the propane and automotive industries.

NOTE: Some autogas fuel systems use European components. In these cases the manufacturer's literature or diagnostic software may use European units or references.

### Adel Clamp

A plastic or metallic strip, usually provided with an insulator, used to secure electrical wiring, fuel lines or coolant lines. Sometimes called a "J clip" or a "P clip" due to its shape.

### AHJ

Authority having jurisdiction. A governmental body or other entity that enforces a code or standard or approves equipment or procedures, e.g., codes or standards relating to propane autogas.

### Air-Fuel Ratio

The ratio of air to fuel in a mixture, expressed either by volume or by weight. For propane, the ideal air-fuel ratio by volume is 24:1, i.e., 24 parts air to 1 part fuel. The ideal ratio by weight is 15.5:1, i.e., 15.5 pounds of air to 1 pound of fuel.

An air-fuel ratio may also be expressed as an AF number. In this system, the ideal ratio is defined as  $AF = 1$ . An AF ratio greater or less than 1 indicates a rich or lean mixture, respectively. AF 1.1 means the mixture is 10 percent richer than the ideal ratio, and AF 0.9 means the mixture is 10 percent leaner than the ideal ratio. See also Lambda.

### ALDL

Assembly Line Diagnostic Link. A connection located near the steering column of a vehicle that allows OBD-2 access to the vehicle's electronic control module. See OBD-2, SAE J1939.

### ANSI

American National Standards Institute. ANSI sets standards that are often adopted by regulatory authorities. See AHJ.

### ASME

American Society of Mechanical Engineers. ASME sets manufacturing standards for propane autogas containers, including standards for maximum design pressure, testing, marking, and fabrication.

### ASTM

ASTM International, formerly American Society for Testing and Materials. ASTM sets standards for physical components of autogas systems such as valves and piping. Testing standards include, but are not limited to, pressure, temperature, accuracy during manufacturing, and corrosion resistance.

**Autogas** The international term for LP-gas mixtures used to propel highway vehicles. In the U.S., autogas is at least 90 percent propane, and the terms “autogas,” “propane,” and “propane autogas” are used interchangeably. Elsewhere “autogas” may refer to mixtures of propane and butane in various proportions. See also HD-5.

### **Autostop**

A float-actuated valve inside a propane fuel tank that automatically prevents the tank from being filled past the 80 percent liquid level. See OPD.

### **Bifuel**

A vehicle capable of operating on either of two fuels, one at a time, e.g., either autogas or gasoline. See Dual Fuel.

### **California Title 13**

The part of the California Code of Regulations that sets out California Air Resources Board (CARB) emissions standards.

### **CAN/CSA-B.149.5-10**

The Canadian Standards Association’s installation code for propane fuel systems and tanks on highway vehicles.

### **CARB**

California Air Resources Board, sometimes abbreviated ARB. The state agency that sets emission standards for vehicles in California. Any converted vehicle bought or sold in California must meet CARB emission standards. Some other states adopt CARB emission standards.

### **Center of Gravity**

The point on a vehicle around which the vehicle’s weight is equally distributed in all directions: front to rear, left to right, and top to bottom. The center of gravity can change due to momentum and weight shifts during cornering, acceleration, and braking, or by adding or removing components whose weight may affect the vehicle’s handling.

### **CFR**

Code of Federal Regulations. Federal transportation regulations, including those related to transportation of propane, are codified in Title 49 of the CFR.

### **CGA**

Compressed Gas Association. CGA develops and promotes safety standards and safe practices in the industrial gas industry.

### **Code**

A legally enforceable standard that has been adopted by an authority having jurisdiction.

### **Commercial Propane**

LPG sold for general use, e.g., for residential heating and cooking. Commercial propane is a blend of LP gases consisting primarily of propane, with some propylene, butylenes and refinery remnants. No formal standard exists for the composition of commercial propane. The Gas Processors Association’s specification for commercial propane limits sulfur content to 185 part per million by weight.

**Converter**

Generic term for a device that converts propane liquid to propane vapor and incorporates a pressure regulator that reduces tank pressure to the pressure required by the engine. The term is sometimes used interchangeably with vaporizer, reducer, regulator or vaporizing regulator. See Vaporizer.

**Convuluted Wire Loom**

Flexible, ribbed plastic tubing that is split open for the insertion of a wire harness. The convuluted wire loom provides abrasion resistance and cosmetic enhancement. Convuluted wire loom rated for automotive use should resist heat and UV degradation.

**Crimp Connector**

A connector used to join two or more pieces of wire by squeezing them together in a small metal tube. Applying solder to the coupling provides additional mechanical strength. Most crimped couplings are solderless and have a loose plastic insulating sleeve. Others incorporate low-temperature solder and heat shrink tubing in addition to the crimp.

**Cylinder** A portable fuel container designed, tested, marked, and fabricated in accordance with standards developed by the U.S. Department of Transportation.

**DOT** The U. S. Department of Transportation. DOT is charged by Congress with setting the rules and standards for transportation safety set out in Title 49 of the Code of Federal Regulations, including the design pressure, testing, marking, and fabrication requirements for portable propane cylinders.

**DTC** Diagnostic Trouble Code. Generic term for a code sent from a vehicle's electronic control module indicating a specific malfunction in the vehicle's emissions control system. The code may be cross-referenced to help identify the fault. See ECM/PCM/ECU.

**Dual Fuel** A vehicle capable of operating on a mixture of two fuels at the same time, e.g., both autogas and diesel. See Bifuel.

**ECM/PCM/ECU**

Electronic Control Module, Powertrain Control Module, and Electronic Control Unit, respectively. The terms are interchangeable and do not identify a manufacturer or brand-specific component. An ECM/PCM/ECU controls all engine functions, including emission controls and throttle position. Some aftermarket fuel systems use a "slave" or "supplemental" module as an interceptor or translator. Dedicated liquid propane fuel injection systems typically use the original PCM, repurposed for propane.

**EN 67** The European standard for certifying autogas fuel-system components.

**EPA** U.S. Environmental Protection Agency. EPA oversees the testing and certification of engine fuel systems to verify compliance with applicable emissions standards. Vehicles converted to propane must comply fully with the EPA emission regulations in effect at the time of the conversion.

### **Fixed Maximum Liquid Level Gauge**

A small (#54 drill size) valve located at the 80 percent full level of an autogas fuel tank. It may be used during filling to indicate that the tank has reached the maximum full level. The valve may be remotely plumbed if the tank is not accessible during filling. Also called a “spitter,” “bleeder,” “vent,” “spew,” “outage” and “80 percent” valve.

### **Flare Fitting**

A pair of fittings whose mating surfaces meet, typically at SAE 45°, capturing a section of tubing that has been expanded to a matching 45° flare. There will always be two fittings, one male, the other female, with matching surfaces.

### **Flow Control Module**

A component of a liquid propane fuel injection system that allows partially vaporized fuel to be flushed from the fuel rails back to the fuel tank.

**FMVSS** Federal Motor Vehicle Safety Standards. Comprehensive safety standards for motor vehicles codified in Title 49 of the Code of Federal Regulations. FMVSS standards apply to tank retention systems and to the location of critical vehicle components, including brake and fuel lines.

### **Fuel Filter**

Fuel filters trap debris particles, typically 40 microns down to 10 microns (40 $\mu$ -10 $\mu$ ) in size, that may be partially dissolved or suspended in fuel. These particles include rust, tank scale, and rubber compounds from deteriorating hoses that may enter the fuel during transportation or storage. Typical filter media are pleated paper, sintered bronze, wound or woven string, compressed polyester or cotton fiber or fiber resin.

### **Fuel Injector**

An electrical solenoid, controlled by a vehicle’s computer, that precisely meters fuel to the cylinders of an engine. The duration of the energized pulse determines how much fuel enters the cylinder. See Pulse Width.

### **Fuel Transfer Hose**

A small hose that connects a fuel injector to the intake manifold nozzle. The length and location of the fuel transfer hose should be dictated by the manufacturer to comply with emission certifications. See Nozzle.

**Gas** Any substance in the gaseous (vapor) phase, such as water vapor or propane vapor.

**G-Force** A measure of a component's ability to stay attached to a vehicle. A component required to withstand a "4-G force" must be able to withstand a static force equal to 4 times its own weight without becoming detached. This term is most frequently used to describe the ability of a fuel tank to remain in the vehicle in the event of an accident.

**HD-5** A specification for propane autogas. "HD" means heavy duty, and "5" means no more than 5 percent propylene by volume is permitted in the fuel mixture. HD-5 propane typically conforms to ASTM D-1835, which specifies a maximum of 5 percent propylene, a minimum of 90 percent propane, and the remainder trace gases. A maximum vapor pressure of 208 psig at 100°F effectively limits the amount of higher-pressure ethane in the mixture.

**HD-10** Unofficial term for LPG with up to 10 percent propylene that meets the specifications set out in the California Code of Regulations, Title 13, Section 2292.6.

### Heat Shrink Tubing

Tubing that shrinks when heat is applied, typically used to provide insulation for electrical wiring connections.

### Heavy Ends

Semi-soluble organic compounds, typically consisting of large (C<sub>20+</sub>) molecules. When propane is vaporized inside a vaporizer or converter, these heavier compounds may be partially vaporized or left behind in the form of light oils, heavier greases or paraffins.

### Hydrocarbon

Any organic compound consisting entirely of hydrogen and carbon. Propane is a hydrocarbon made up of three carbon atoms and eight hydrogen atoms (C<sub>3</sub>H<sub>8</sub>).

### Hydrostatic Pressure Relief Valve

A pressure relief valve that opens between 400 and 500 psig to relieve pressure on a hose that may have fuel trapped between two closed valves. When a hydrostatic pressure relief valve is incorporated in a "tee" configuration where two fuel tanks are coupled together, the valve is called a "hydrostatic check tee."

### Inertia Switch

A device that detects a rapid deceleration (collision or impact) and immediately shuts off the fuel pump. Some autogas fuel systems use this circuit or the controls that actuate this circuit to control the fuel lockoff. All such systems deactivate the fuel lockoff after three to five seconds if no engine RPM is detected with the ignition key in the "on" position.

### LPG

Liquefied Petroleum Gas. Any material having a vapor pressure not exceeding that allowed for commercial propane that is composed predominantly of the following hydrocarbons, either by themselves or as a mixture: propane, propylene, butane (normal or iso-butane) and butylene.



**LPI** Liquid Propane Injection. A technology in which propane liquid instead of propane vapor is injected into the intake manifold of an engine. See LPFFI.

**LPFFI** Liquid Phase Propane Fuel Injection. See LPI.

### Manual Control Valve

A manually operated valve that, when fully closed, prevents fuel from flowing to the engine from the tank. Electrically operated control valves have a manual override that performs this function.

**MIL** Malfunction Indicator Light. An amber dashboard light indicating that service is needed but the fault is not an emergency. Also known as the Check Engine Light or the Service Engine Soon light.

**MSDS** Material Safety Data Sheet. A document that describes the physical and chemical properties of a product and provides health and safety information related to the product's storage, use and disposal.

### Multivalve

A component of liquid propane fuel injection systems that combines several valves, solenoids, fittings, and sensors into a single valve assembly.

**NFPA** National Fire Protection Association. NFPA publishes codes and standards that are adopted by many U.S. jurisdictions. NFPA 58, *Liquefied Petroleum Gas Code*, includes standards on propane retrofit fuel systems.

**Nozzle** An adapter inserted in the intake manifold that receives the fuel transfer hose. The fuel system manufacturer should specify the location of the nozzle to comply with emission certification requirements. See Fuel Transfer Hose.

**NPT** National Pipe Thread. NPT is the thread pitch and taper standard used for fitting tapered pipe joints and connections in the U. S.

**OBD-1** Manufacturer-specific diagnostic codes, tools and procedures used from about 1988 through 1995, or through 1996 in some heavy-duty applications. See Appendix B.

**OBD-2** The universal SAE J1939 Diagnostic Standard applicable to all vehicles made or sold in the United States after 1996. Some vehicles became subject to OBD-2 beginning in 1994. See Appendix B.

**Octane** A measurement of a fuel's ability to resist detonation. The higher the octane rating, the harder the fuel is to ignite and the longer it will burn once ignited. Octane ratings do not measure the energy content of the fuel.

A fuel's research octane number (RON) is calculated using a laboratory engine with a variable compression ratio, which is increased until the test fuel detonates. The fuel's motor octane number (MON) is calculated using the same test engine after adjusting for factors such as fuel temperature, increased engine speed and variable ignition timing. MON values are typically about 10 points lower than RON.

Research and motor octane values are totaled and averaged ( $R + M / 2$ ) to yield the pump octane rating posted on a fuel dispenser. HD-5 propane has a pump octane rating of about 100-105, depending on the fuel mixture.

**Odorant** A man-made compound added to fuel gas to aid in leak detection. The most commonly used odorant is ethyl mercaptan (ethanethiol), a sulfur-based compound that smells like rotten eggs. NFPA 58 states that odorization at the rate of 1 pound of ethyl mercaptan per 10,000 gallons of propane has been recognized as an effective odorant.

**OEM** Original Equipment Manufacturer. May refer to the manufacturer of a vehicle, a fuel system or an individual fuel-system component.

### **Pipe Threads**

Tapered threads cut on either the inside or outside of a pipe or fitting. When joined, the threads create a gas or liquid seal. National Pipe Thread standards specify the thread pitch and taper used for tapered pipe joints and connections in the U. S. The taper is 1/16" per inch, which is the same as 3/4" per foot (the angle 1° 47'). Also called "tapered threads" or "National Pipe Threads."

### **Pipe Thread Sealer**

A liquid, paste, tape or semi-solid product that lubricates and seals the tapered threads in a threaded pipe joint.

**Piping** Any part of the fuel system that conveys fuel from the tank to the engine. Piping is typically rigid or semi-rigid metal but may be fabricated from other materials. See Tubing.

**PPE** Personal Protective Equipment. Typically safety glasses and properly rated work gloves. Additional protection, depending on the job, may include fire-rated clothing, steel-toe shoes, face shield or hearing protection.

### **Pressure Relief Valve**

A valve located in the vapor space of a fuel container that opens at a pre-set pressure (typically 312 psig). The valve controls the maximum pressure inside the fuel container by venting fuel vapor to the atmosphere through a duct or hose in a manner described by code.

**Propane** One of the four regulated liquefied petroleum gases: propane, propylene, normal butane and iso-butane. The term “propane” is often used to refer to a mixture of LP gases that is predominantly propane. See Autogas.

**Purging** Removing any air, moisture or vaporized contents from a container. Purging may be accomplished by either pressure or vacuum, depending on the contents of the container. A container that has ever contained propane or another combustible product must never be vacuum purged. See Appendix D.

**SAE** SAE International, formerly Society of Automotive Engineers. A professional engineering organization that develops and publishes standards for the automotive and aerospace industries.

### **SAE J1939**

The SAE computer protocol for the diagnostic connector link (DCL) that transmits diagnostic information and other data to and from vehicle components. All vehicles made or sold in the United States since 1996 use the SAE J1939 standard. See ALDL.

### **Safety Box**

The area under the hood generally considered to be the safest part of a vehicle. The safety box is bounded by the inside of the front fenders, the bulkhead or firewall, and the radiator core support.

### **Saturation Pressure**

The minimum pressure required at a given temperature to keep propane in the liquid phase. If the pressure is reduced or the temperature increases, propane will vaporize and seek to return to its saturation pressure. If the pressure is increased or the temperature decreases, propane will remain a liquid. See Vapor Pressure.

**Solder** A metallic alloy, typically tin and lead in varying proportions, used to join metal objects at temperatures (typically 360°F) high enough to melt the solder, but lower than the melting point of the workpieces.

### **STFT/LTFT**

Short Term Fuel Trim / Long Term Fuel Trim. Fuel trim refers to the continual adjustment of an engine’s air-fuel ratio by the vehicle’s powertrain control module. STFT refers to adjustments made in response to temporary conditions. LTFT refers to longer-term adjustments. Trim values are used during diagnostics to determine how the vehicle has been performing or to program the auxiliary PCM.

Fuel trim values are expressed in percentages. Positive values adjust for a lean mixture (fuel is added). Negative values adjust for a rich mixture (fuel is subtracted). LTFT values generally should not exceed  $\pm 10$ -25 percent or the vehicle computer may set a fault code.

**Stoichiometry**

SAE standard J1829 defines “stoichiometric air-fuel ratio” as “the mass of air required to burn a unit mass of fuel with no excess of oxygen or fuel left over.” An engine running at AF=1 or at Lambda ( $\lambda$ )=1 is operating at stoichiometry. See Air-Fuel Ratio, Lambda.

**Submersible Fuel Pump**

A fuel pump located inside a fuel tank and designed to be fully submerged in liquid fuel. Submerging the fuel pump keeps it cool and lubricated during operation.

**Swaged** The process of securing a fitting inserted in a hose by installing a metal collar around the hose and compressing (swaging) the collar around the hose and the fitting to form a permanent coupling.

**Tank** A propane fuel container designed, tested, marked and fabricated in accordance with ASME standards.

**Thread Lock Seal**

A compound applied to a threaded coupling that seals the joint and locks the device in place. Thread lock sealing compounds cure in the absence of air and keep the device from unscrewing due to vibration or tampering.

**Toroidal** Donut-shaped. A toroidal tank can fit in the spare tire location under the rear of a pickup truck or in the spare tire well of a smaller vehicle.

**Transducer**

A device that converts temperature or pressure information to an electrical signal and transmits the signal to the vehicle’s computer.

**Tubing** A part of the fuel system that conveys fuel from the tank to the engine compartment. See Piping.

**Type III Hose**

A fuel hose standard that requires a non-permeable inner liner, typically nylon or Teflon, and permanent hose-end terminations. Type III hose requires certification by an approved hose manufacturer and documented pressure testing.

**Vaporizer** The most common term for the device in a propane autogas fuel system that converts liquid fuel to vapor. See Converter.

**Vapor Pressure**

The pressure exerted by a propane vapor in equilibrium with propane liquid inside a closed container. See Saturation Pressure.

**Zip Tie** A nylon strip with an integrated gear track that has a ratchet and a small opening on one end. The end of the strip is inserted into the ratchet opening and pulled tight. The ratchet engages the gear track and keeps the strip from being pulled back out. Zip ties for automotive use are rated for heat and ultraviolet resistance.





Copyright © 2011 Propane Education & Research Council



Propane Education & Research Council  
1140 Connecticut Avenue, N.W. Ste. 1075  
Washington, D.C. 20036  
(202) 452-8975

PRC 003600